

## Product Guide

# Force Measurement Equipment Safety Guide



To avoid situations that may cause personal injury or equipment damage, read and understand the following instructions when applying force to measuring instruments.

1. When loading through a steel ball, the instrument should have a conical ball seat of the recommended size for the ball size (see Figure 2), and the opposing surface should have a similar ball seat. Alternately, a soft steel pad of sufficient size and thickness may be used instead of a ball seat on the opposite surface for capacities of 200,000 lbs. and less. The force must be applied axially within one degree. The bottom boss of the load cell or other instrument must bear against a flat, hardened steel surface and, if possible, should be restrained (see Figure 1).

2. When applying force to a load cell or other force-measuring instrument through a steel ball, be certain that the ball is made of hardened chrome alloy steel and that it is the recommended size (see Figure 2) to withstand the force applied. **Never use a carbide ball.** Carbide is brittle and will shatter under load.

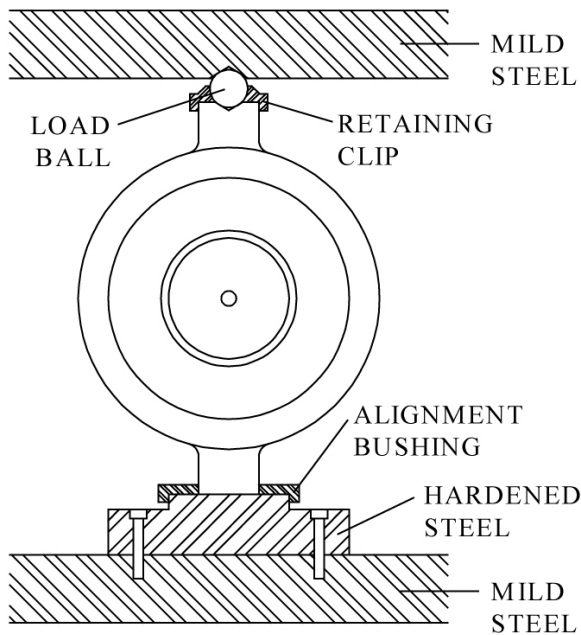
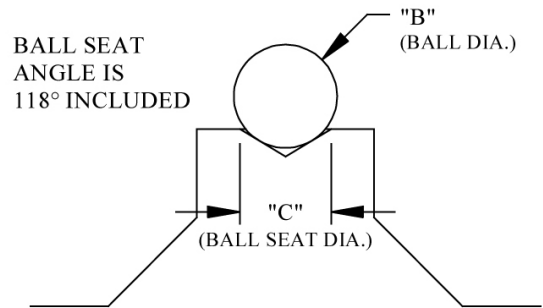


Figure 1



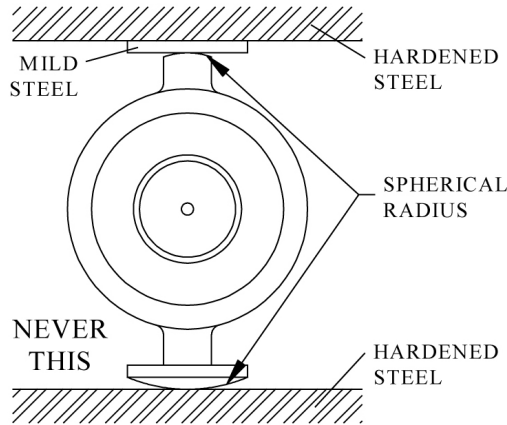
LOAD BALL MUST BE HARDENED CHROME ALLOY STEEL.

22,000 LBF.	10 mm.	17/64
220,000 LBF.	1 1/2	1
120,000 LBF.	7/8	3/4
66,000 LBF.	5/8	1/2
33,000 LBF.	7/16	3/8
MAX. CAP.	"B"	"C"

Figure 2



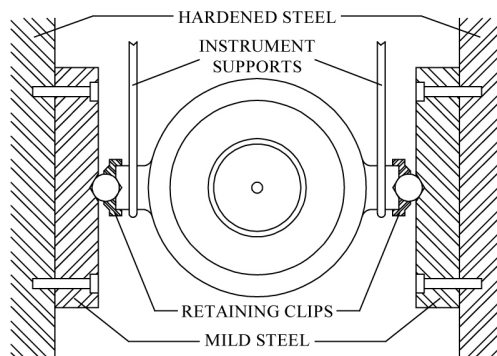
3. **Do not load between unstable surfaces.** Under load, the instrument could be ejected from the machine with tremendous force. Never use a set-up where two spherical surfaces oppose one another without making the appropriate adapters to contain the instrument. Morehouse has developed special adapters for this type of loading. The instrument could be ejected from the machine without the appropriate adapters with tremendous force. See Figure 3 for an example of what not to do.



Never use a set-up like this where two spherical surfaces oppose one another under load. The instrument could be thrown from the machine with tremendous force.

**Figure 3**

4. **Do not load between two steel balls unless the loading components are mechanically restrained to prevent any possible lateral movement when loaded.** Additionally, the surfaces of the components must have properly sized ball seats, the ball seats of the components must be axially aligned, and ball retainer clips should be used. See Figure 4.



Never use this setup unless load-bearing components are restrained from any lateral movement under force. Do not use this method for loads over 50,000 lbf.

**Figure 4**



5. When using tension member assemblies with mating spherical surfaces, be sure they are properly installed. See Figure 5. Morehouse Quick-Change Tension members (pictured below) are designed to help eliminate eccentric loads, resulting in a more accurate and safer force application.

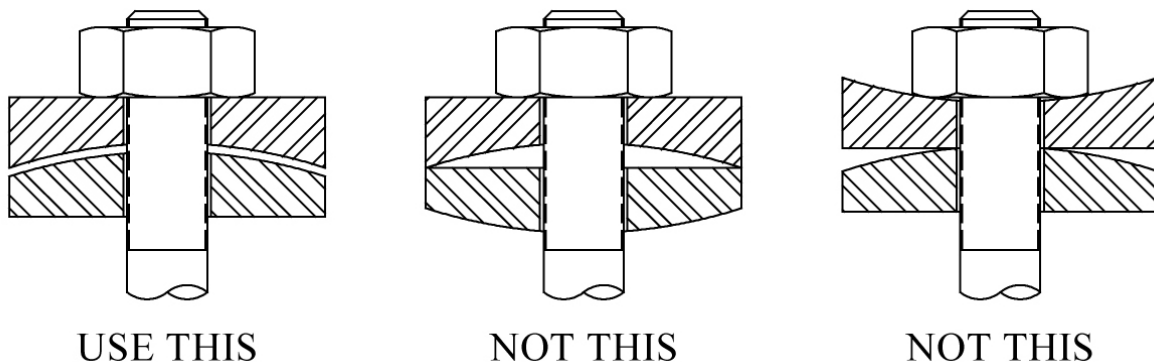


Figure 5

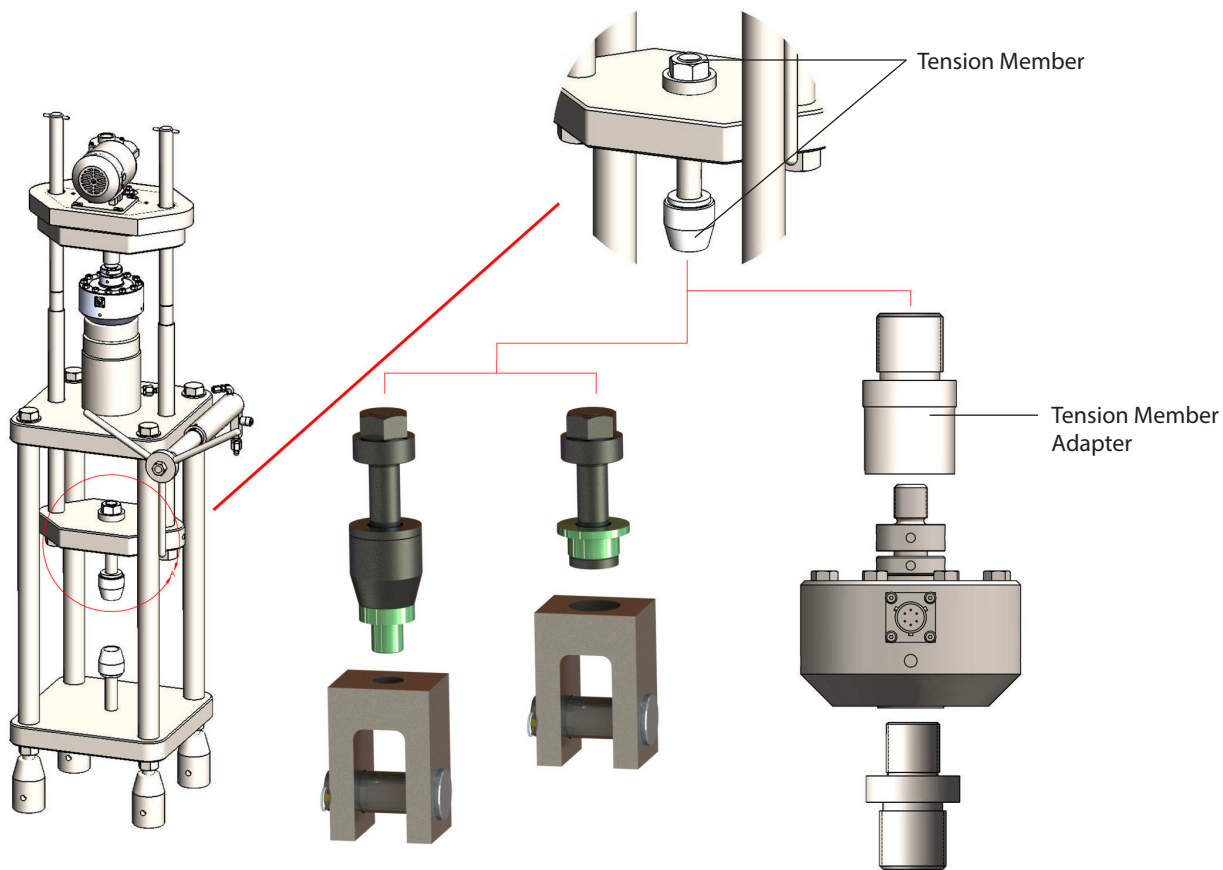
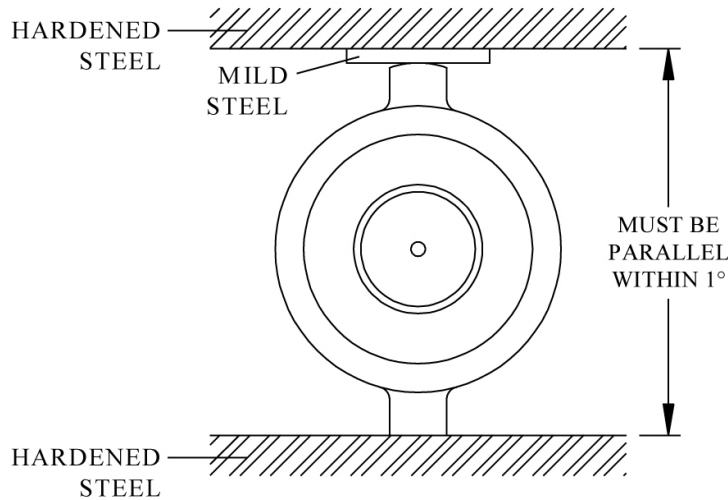


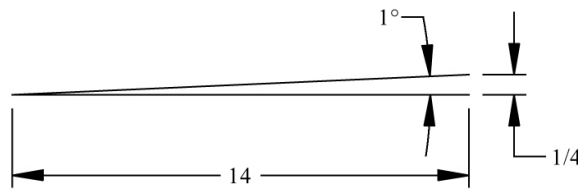
Figure 6



6. Do not load between surfaces that exceed one-degree deviation from parallel. See Figure 7.

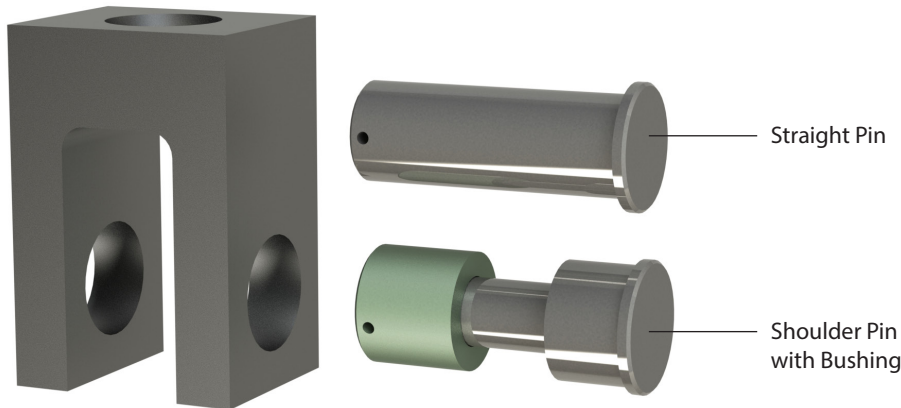


Axis of load application must be parallel within 1°. See instructions for recommended sizes and load ratings.

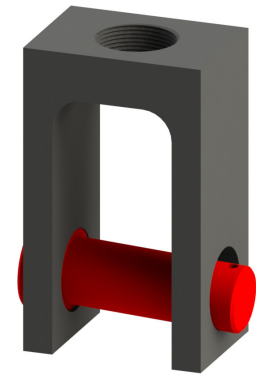


**Figure 7**

7. When using a Clevis assembly, follow the manufacturer’s specification for the pin diameter to use the correct Clevis pin. A straight pin or shoulder pin with bushing should be used with the Clevis. Do not put a small pin in a large hole. Concentrated forces will fatigue the Clevis, shortening the life space of the set.

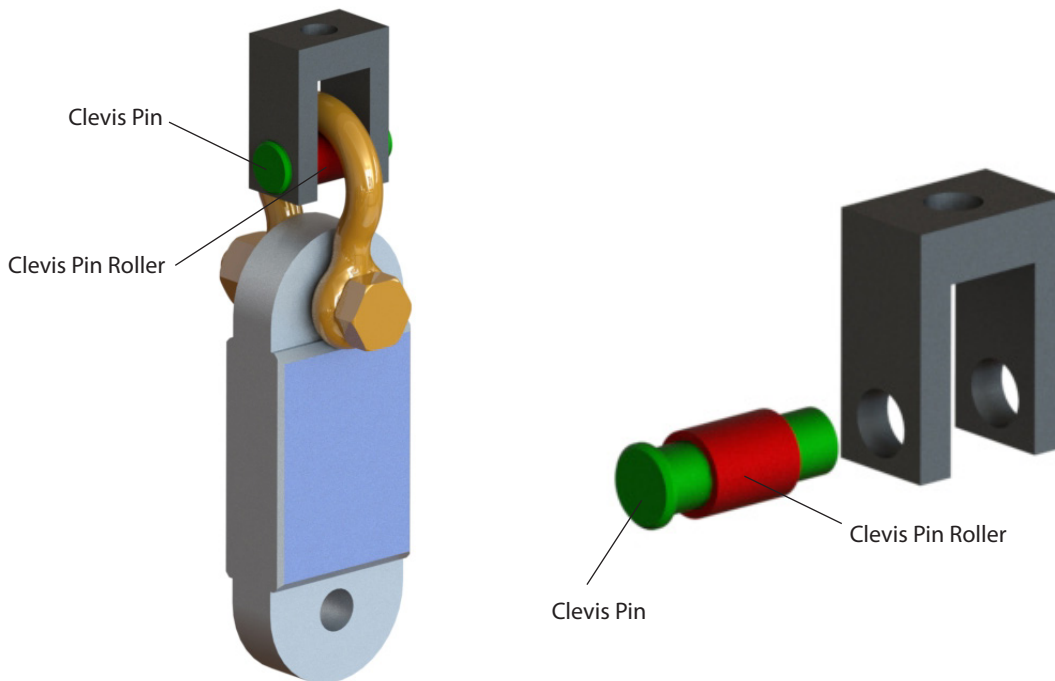


**Figure 8: Clevis and Pins**



**Figure 9: Incorrect Use with Bushing Missing**

8. When calibrating a dynamometer with loading shackles, use a roller to protect against concentrated forces. Without the roller, the shackle can damage the pin.



**Figure 10: Clevis Pin Application**

Applying forces, particularly large forces, to equipment and instruments is inherently dangerous. This document does not, and cannot, foresee all safety considerations in your testing and application environments. It is important to give careful consideration to any application of force. Read and understand all instructions and precautions applicable to using the instrument and/or machines being used to apply the force. If there are questions or doubts about using Load Cells, Proving Rings, or other force measuring instruments, contact us at 717-843-0081 or [info@mhforce.com](mailto:info@mhforce.com).

Most importantly, any adapter or accessory you may design, make, or purchase with a calibrating or force-measuring instrument must be of proper design and made from steel of the proper strength to withstand the forces to which it is subjected. Adapters and accessories should be test-loaded under safe conditions before using with an instrument. Equipment should not be used beyond its maximum rated capacity. Failure to use the proper strength material may result in serious injury or death.

Keeping the line of force pure, also known as free from eccentric forces, is key to calibrating load cells. A critical component for safe force measurements is to use the proper compression and tension adapters. For a comprehensive guide, download our [Force Calibration Adapters Guidance](#).



**Figure 11: Load Cell Showing Eccentric Forces**