



Morehouse
THE FORCE IN CALIBRATION SINCE 1925

PM-2121
Rev. 3/2022

ISO/IEC 17025 / ANSI/NCSLI Z540.3 Accredited

Operation and Instruction Manual

Ring Force Gauge



Morehouse Instrument Company, Inc.
1742 Sixth Ave., York, PA 17403-2675 USA



P: (717) 843-0081
F: (717) 846-4193



info@mhforce.com
www.mhforce.com



Table of Contents

Safety	3
Introduction	3
Preparation for Loading	4-5
Operation	5-7
Compression and Tension Setup	6
Indicator Operation	7
Calibration	8
Calibration Procedure	
Frequency of Calibration	
Maintenance	9
Upgrade from Analog Ring Force Gauge	9
Temperature Correction for Ring Force Gauges	10-11
Fahrenheit Scale (Drawing 99332)	10
Centigrade Scale (Drawing 99332-1)	11
Warnings	12

Safety

For general guidelines about force calibration safety, refer to the Morehouse Force Measurement Equipment Safety guide [PG-9000](#). In addition, the following safety practices must be exercised when using a Ring Force Gauge.

- Read the instruction manual carefully and ensure that anyone who intends to operate the machine has proper training on safe practices of using a portable calibrator.
- Inspect all components of the Ring Force Gauge, and any components used from a connection before use to ensure all parts are free of defect and are attached properly.
- Ring Force Gauges can only be used under the rated capacity. Overloading a Ring Force Gauge may cause a dangerous situation for the user and permanently damage the instrument.
- To avoid situations that may cause personal injuries wear eye protection at all times when using a Morehouse Ring Force Gauge or any other force measuring instrument.
- Any adapter or accessory you may design, make or purchase for use with a portable calibrator, or force measuring instrument, must be of proper design and made from steel of the proper strength to withstand the forces to which it is subjected. It is most important that adapters and accessories be test loaded under safe conditions prior to actual use with an instrument. Equipment should not be used beyond its maximum rated capacity. Failure to use the proper strength material may result in serious injury or death.

Applying forces to equipment and instruments is inherently dangerous. This document does not, and cannot, foresee all safety considerations in your testing and application environments. It is important to give careful consideration to any application of force.

Introduction

The Ring Force Gauge is relatively simple to operate. If maximum accuracy is desired the Ring Force Gauge should be placed near the location where it is to be used and allowed to stabilize at the ambient temperature that will prevail during use. Deviations from the temperature at which the Ring Force Gauge was calibrated will cause errors of approximately 1% for every 70 degrees F.

Safety

For general guidelines about force calibration safety, refer to the Morehouse Force Measurement Equipment Safety guide [PG-9000](#). In addition, the following safety practices must be exercised when using a Ring Force Gauge.

- Read the instruction manual carefully and ensure that anyone who intends to operate the machine has proper training on safe practices of using a portable calibrator.
- Inspect all components of the Ring Force Gauge, and any components used from a connection before use to ensure all parts are free of defect and are attached properly.
- Ring Force Gauges can only be used under the rated capacity. Overloading a Ring Force Gauge may cause a dangerous situation for the user and permanently damage the instrument.
- To avoid situations that may cause personal injuries wear eye protection at all times when using a Morehouse Ring Force Gauge or any other force measuring instrument.
- Any adapter or accessory you may design, make or purchase for use with a portable calibrator, or force measuring instrument, must be of proper design and made from steel of the proper strength to withstand the forces to which it is subjected. It is most important that adapters and accessories be test loaded under safe conditions prior to actual use with an instrument. Equipment should not be used beyond its maximum rated capacity. Failure to use the proper strength material may result in serious injury or death.

Applying forces to equipment and instruments is inherently dangerous. This document does not, and cannot, foresee all safety considerations in your testing and application environments. It is important to give careful consideration to any application of force.

Introduction

The Ring Force Gauge is relatively simple to operate. If maximum accuracy is desired the Ring Force Gauge should be placed near the location where it is to be used and allowed to stabilize at the ambient temperature that will prevail during use. Deviations from the temperature at which the Ring Force Gauge was calibrated will cause errors of approximately 1% for every 70 degrees F.

Preparation for Loading

Compression

If the Ring Force Gauge is to be loaded against the spherical surface on the top boss, then a piece of cold rolled steel (loading pad) should be inserted between the top boss or button and the upper surface against which it will bear. This will prevent the button from causing an indentation in the upper surface. Following is a list of recommended sizes for the cold rolled steel to be used:

- Capacities through 50,000 lbf – 2" x 2" x 0.5" Thick
- Capacities 50,001 through 100,000 lbf – 3" x 3" x 0.5" Thick
- Capacities 100,001 through 200,000 lbf – 4" x 4" x 0.75" Thick
- Capacities 200,001 through 500,000 lbf – 4" x 4" x 1.5" Thick
- Capacities 500,001 through 1,000,000 lbf – 5" x 5" x 2.0" Thick

The surface on which the lower boss will bear should be flat to minimize non-axial loading. If the Ring Force Gauge is to be loaded using a load ball in place of the spherical surface on the top boss, then the surfaces opposing the ball should have a ball seat approximating the dimensions shown on in Figure 1. When loading through a steel ball, be certain that the ball is made of hardened chrome alloy steel and it is the recommended size to withstand the force applied. Never use a carbide ball because carbide is brittle and will shatter under load.

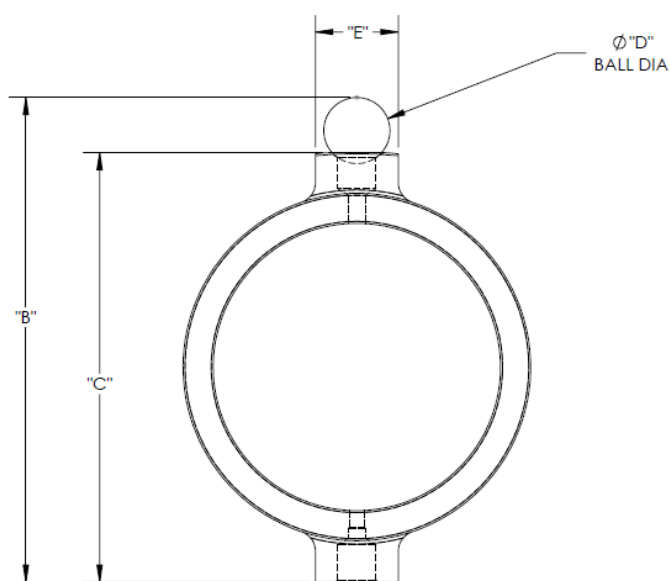

Capacity (lbf)	A Dia.	B	C	D Dia.	E Sq
50	0.75	6.80	6.00	0.88	0.75
100	0.75	6.80	6.00	0.88	0.75
200	0.75	6.80	6.00	0.88	0.75
500	0.75	6.80	6.00	0.88	0.75
1,000	0.75	6.80	6.00	0.88	0.75
2,000	0.75	6.80	6.00	0.88	0.75
5,000	0.88	7.38	6.50	1.00	1.25
10,000	0.88	7.38	6.50	1.00	1.25
20,000	0.88	7.88	7.00	1.00	1.25
50,000	0.88	10.38	9.50	1.00	1.75
100,000	0.88	11.88	11.00	1.00	2.50

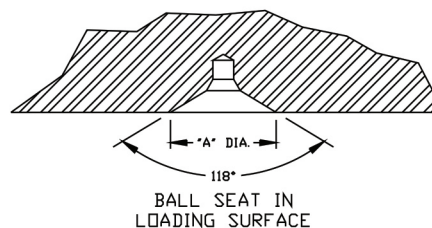

Figure 1: Ball Seat Dimensions

Tension

When mounting a tension type Ring Force Gauge keep any special attachments or adaptors in as close alignment as possible.

Operation

After mounting the Ring Force Gauge in the press or other assembly in which the mechanical forces are to be measured, the force gauge should be exercised two or three times to stabilize it. Load the Ring Force Gauge to its capacity or the force to which it is to be used, whichever is lower, and release it. After exercising the Ring Force Gauge reset it to zero, if necessary, by rotating the bezel of the indicator.

When loading a force gauge that has tension capabilities, be sure the indicator is not sticking or “hanging-up” and it is properly following the loading of the force gauge so that it is not accidentally overloaded.

The versatile ring force gauge can be applied in many different ways and applications are limitless. It is supplied with tapped holes in external bosses so it can be easily fitted with special adaptors, accessories, or mounting brackets of base plates that are incorporated into an application. Please contact us if you have any questions about how the Ring Force Gauges can be applied, or about adapters you may need.

Compression and Tension Setup

Model FRC

Designed and calibrated to measure compressive forces only

Capacity	Setup
Lower than or equal to 2,500 lbf	A base adapter is threaded into the lower boss of the force gauge to provide stability.
	A load button is threaded into the upper boss to help with load line alignment.
Higher than 2,500 lbf	Larger bosses keep the force gauge stable. The upper boss has a spherical surface which can be loaded against directly.
	A chamfer in the upper boss can accommodate a load ball. A load ball is recommended to help with better load line alignment.

Model FRT

Designed and calibrated to measure tension forces only

Capacity	Setup
Lower than or equal to 10,000 lbf	A set of two rod ends can be used to measure tensile forces and help with tensile load line alignment.
Higher than 10,000 lbf	Threaded upper and lower bosses for special adapters. Typically, gauges in this capacity range are used for special high force measurement applications and need special adapters for their application. Morehouse can help users find safe and reliable solutions for their specific application.

Other adapters can be used to generate tensile loading setups. Prior to using any tension adapters, the operator must ensure the adapters are rated for the force that will be applied to the instrument during the force measurement process. Morehouse manufactures a large variety of tension adapters which can be used with Ring Force Gauges to produce tension force calibration setups for almost any application.

Indicator Operation

Since the accuracy of the Ring Force Gauge is directly dependent upon the dial indicator, the Ring Force Gauge should be handled with reasonable care. Occasionally, as with most dial indicators, a slight “hanging-up” of the pointer may be noticeable. A light tapping of the indicator with a pencil will free the pointer. If it is desired to use the Ring Force Gauge to its highest degree of accuracy the indicator should be tapped at each load to be sure friction in the indicator is not causing an error.

Do not oil the indicator. If the indicator sticks after a period of inactivity, then work the spindle up and down several times to free the movement. The spindle may be worked up and down by inserting a piece of shim stock between the contact point of the indicator spindle and the lower anvil of the ring and then alternately lifting and releasing the spindle over its entire range.

Calibration

Calibration Procedure

Morehouse uses deadweight force calibrating systems to calibrate Ring Force Gauges up to 120,000 lbf in both compression and tension modes. For higher capacities, secondary force standards are used which are calibrated directly by National Institute of Standards and Technology (NIST).

Frequency of Calibration

The question, “How often should a Ring Force Gauge be calibrated?”, is difficult to answer. Some specifications require gauges that are used to check or calibrate production, general inspection devices, and gauges should be recalibrated annually or biannually. However, where there is no particular specification that must be complied with, the following general rules may be used as a guide to determine the frequency of calibration:

1. When the Ring Force Gauge is used on a daily basis under conditions where it may be subjected to vibration and infiltration of dirt and grit, and the utmost in accuracy within its limits is desired, semi-annual recalibration is suggested. If the force gauge is not subjected to possible infiltration or contamination under the above conditions, or the highest possible degree of accuracy is not required, annual or biannual recalibration is suggested.
2. If the Ring Force Gauge is used two or three times a week to make general force measurements to the highest possible degree of accuracy, within its limits, annual recalibration is suggested.
3. If the Ring Force Gauge is used four or five times a month to check or calibrate another force measuring device, or machine such as presses, testing machines, load cells, etc., bi-annual calibration is suggested.

Maintenance

Each Morehouse Ring Force Gauge is designed to operate under a specified force capacity. The operator must ensure that the force gauge is not put under forces higher than its rated capacity. Overloading a force gauge may result in permanent deformation of the ring and irreversible damages to the instrument. Additionally, any deformation in the ring will void the calibration of the instrument. In case that any suspicion is raised on whether a Ring Force Gauge has been overloaded, the user must verify the validity of the instrument calibration through proper force calibration procedures.

Upgrade to Digital Ring Force Gauge

A standard analog Morehouse Ring Force Gauge can be upgraded to the Digital Ring Force Gauge. With this upgrade, the operator gets a higher accuracy device, as well as other benefits that come from a digital direct read system. For this upgrade, the analog Ring Force Gauge must be sent to the Morehouse facility for installation of the new parts. After upgrade, all gauges will need to be recalibrated to adjust to the new digital indicator. Contact Morehouse for any additional information or questions about upgrading your analog Ring Force Gauge.

Temperature Correction for Ring Force Gauges

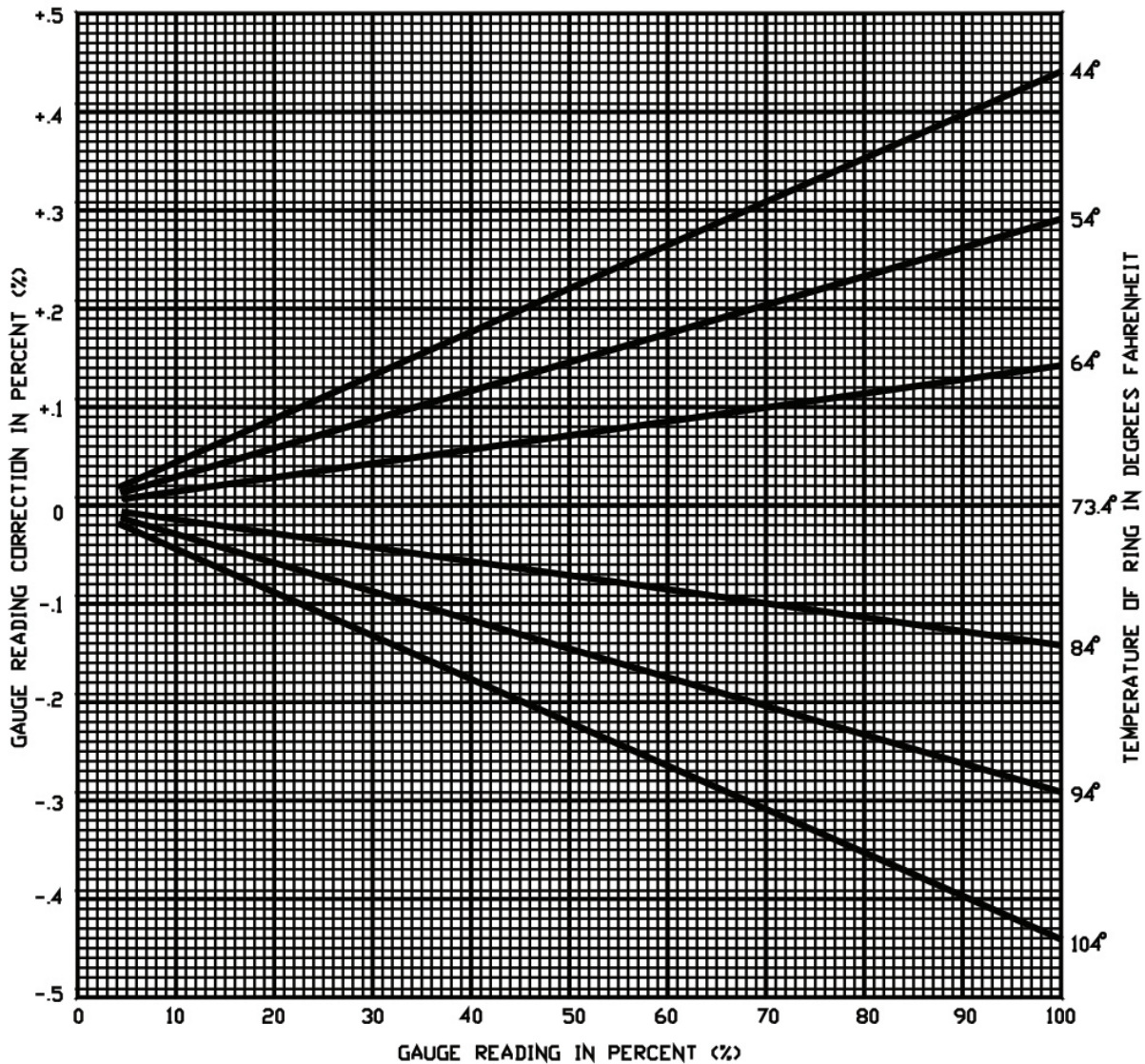

Figure 2: Temperature Correction for Fahrenheit Scale (Drawing 99332)

Temperature corrections may be made using the above graph or by using the following formula

$$D_{73.4} = D_T (1 - .00015(T - 73.4))$$

$D_{73.4}$ = Gauge reading at a temperature of 73.4° Fahrenheit

D_T = Gauge reading at a temperature of T° Fahrenheit

T = Temperature of ring in degrees Fahrenheit

 **WARNING:** Morehouse Instrument Company products are precision instruments for specific force or torque calibration applications. Improper use, exceeding stated capacities, or unauthorized modifications can result in severe injury, death, machine damage, and warranty voiding. Always ensure proper installation, alignment, and use within specified limits. Do not use damaged or visibly compromised components. Refer to your product manual for proper use and specifications. If you have questions about a Morehouse Instrument Company product's capabilities or limitations or to access a manual, please contact your sales representative or email info@mhforce.com.

 Dansk

ADVARSEL: Morehouse Instrument Company produkter er præcisionsinstrumenter til specifikke kraft- eller momentkalibreringsapplikationer. Forkert brug, overskridelse af angivne kapaciteter eller uautoriserede ændringer kan resultere i alvorlig personskade, død, maskinskade og bortfald af garanti. Sørg altid for korrekt installation, justering og brug inden for specificerede grænser. Brug ikke beskadigede eller synligt defekte komponenter. Se din produktmanual for korrekt brug og specifikationer. Hvis du har spørgsmål om et Morehouse Instrument Company-produkts egenskaber eller begrænsninger, eller for at få adgang til en manual, bedes du kontakte din salgsrepræsentant eller sende en e-mail til info@mhforce.com.

 Nederlands

WAARSCHUWING: Morehouse Instrument Company producten zijn precisie-instrumenten voor specifieke kracht- of koppelkalibratietoepassingen. Onjuist gebruik, het overschrijden van de vermelde capaciteiten of ongeautoriseerde wijzigingen kunnen leiden tot ernstig letsel, overlijden, schade aan de machine en het vervallen van de garantie. Zorg altijd voor een correcte installatie, uitlijning en gebruik binnen de gespecificeerde grenzen. Gebruik geen beschadigde of zichtbaar aangetaste onderdelen. Raadpleeg uw producthandleiding voor correct gebruik en specificaties. Als u vragen heeft over de mogelijkheden of beperkingen van een Morehouse Instrument Company product, of om toegang te krijgen tot een handleiding, neem dan contact op met uw verkoopvertegenwoordiger of stuur een e-mail naar info@mhforce.com.

 Vlaams

WAARSCHUWING: Morehouse Instrument Company producten zijn precisie-instrumenten voor specifieke kracht- of koppelkalibratietoepassingen. Onjuist gebruik, het overschrijden van de vermelde capaciteiten of ongeautoriseerde wijzigingen kunnen leiden tot ernstig letsel, overlijden, schade aan de machine en het vervallen van de garantie. Zorg altijd voor een correcte installatie, uitlijning en gebruik binnen de gespecificeerde grenzen. Gebruik geen beschadigde of zichtbaar aangetaste onderdelen. Raadpleeg uw producthandleiding voor correct gebruik en specificaties. Als u vragen heeft over de mogelijkheden of beperkingen van een Morehouse Instrument Company product, of om toegang te krijgen tot een handleiding, neem dan contact op met uw verkoopvertegenwoordiger of stuur een e-mail naar info@mhforce.com.



Français

AVERTISSEMENT: Les produits Morehouse Instrument Company sont des instruments de précision destinés à des applications spécifiques d'étalonnage de force ou de couple. Une utilisation incorrecte, un dépassement des capacités indiquées ou des modifications non autorisées peuvent entraîner des blessures graves, la mort, des dommages à la machine et l'annulation de la garantie. Veuillez toujours à une installation, un alignement et une utilisation corrects dans les limites spécifiées. N'utilisez pas de composants endommagés ou visiblement compromis. Reportez-vous au manuel de votre produit pour une utilisation correcte et les spécifications. Si vous avez des questions sur les capacités ou les limites d'un produit Morehouse Instrument Company, ou pour accéder à un manuel, veuillez contacter votre représentant commercial ou envoyer un courriel à info@mhforce.com



Deutsch

WARNUNG: Produkte der Morehouse Instrument Company sind Präzisionsinstrumente für spezifische Kraft- oder Drehmomentkalibrierungsanwendungen. Unsachgemäßer Gebrauch, Überschreitung der angegebenen Kapazitäten oder unbefugte Änderungen können zu schweren Verletzungen, Tod, Maschinenschäden und zum Erlöschen der Garantie führen. Stellen Sie stets eine korrekte Installation, Ausrichtung und Verwendung innerhalb der angegebenen Grenzen sicher. Verwenden Sie keine beschädigten oder sichtbar beeinträchtigten Komponenten. Beachten Sie Ihr Produkthandbuch für die korrekte Verwendung und Spezifikationen. Wenn Sie Fragen zu den Fähigkeiten oder Einschränkungen eines Produkts der Morehouse Instrument Company haben oder um auf ein Handbuch zuzugreifen, wenden Sie sich bitte an Ihren Vertriebsmitarbeiter oder senden Sie eine E-Mail an info@mhforce.com.



Italiano

AVVERTENZA: I prodotti Morehouse Instrument Company sono strumenti di precisione per applicazioni specifiche di calibrazione della forza o della coppia. L'uso improprio, il superamento delle capacità dichiarate o le modifiche non autorizzate possono provocare gravi lesioni, morte, danni alle macchine e l'annullamento della garanzia. Assicurarsi sempre di una corretta installazione, allineamento e utilizzo entro i limiti specificati. Non utilizzare componenti danneggiati o visibilmente compromessi. Fare riferimento al manuale del prodotto per l'uso corretto e le specifiche. In caso di domande sulle capacità o sui limiti di un prodotto Morehouse Instrument Company, o per accedere a un manuale, contattare il proprio rappresentante di vendita o inviare un'e-mail a info@mhforce.com.



Norsk

ADVARSEL: Morehouse Instrument Company-produkter er presisjonsinstrumenter for spesifikke kraft- eller momentkalibreringsapplikasjoner. Feil bruk, overskridelse av oppgitte kapasiteter eller uautoriserte modifikasjoner kan føre til alvorlig personskade, død, maskinskade og bortfall av garanti. Sørg alltid for riktig installasjon, justering og bruk innenfor angitte grenser. Ikke bruk skadede eller synlig defekte komponenter. Se produktets bruksanvisning for riktig bruk og spesifikasjoner. Hvis du har spørsmål om et Morehouse Instrument Company-produkts egenskaper eller begrensninger, eller for å få tilgang til en manual, vennligst kontakt din salgsrepresentant eller send en e-post til info@mhforce.com.

 Português

AVISO: Os produtos da Morehouse Instrument Company são instrumentos de precisão para aplicações específicas de calibração de força ou torque. O uso inadequado, a superação das capacidades declaradas ou modificações não autorizadas podem resultar em ferimentos graves, morte, danos à máquina e anulação da garantia. Certifique-se sempre da instalação, alinhamento e uso corretos dentro dos limites especificados. Não use componentes danificados ou visivelmente comprometidos. Consulte o manual do seu produto para uso e especificações adequados. Se você tiver dúvidas sobre os recursos ou limitações de um produto da Morehouse Instrument Company, ou para acessar um manual, entre em contato com seu representante de vendas ou envie um e-mail para info@mhforce.com.

 Español

ADVERTENCIA: Los productos de Morehouse Instrument Company son instrumentos de precisión para aplicaciones específicas de calibración de fuerza o par. El uso inadecuado, la superación de las capacidades indicadas o las modificaciones no autorizadas pueden provocar lesiones graves, la muerte, daños en la máquina y la anulación de la garantía. Asegúrese siempre de que la instalación, la alineación y el uso sean correctos dentro de los límites especificados. No utilice componentes dañados o visiblemente comprometidos. Consulte el manual de su producto para conocer el uso y las especificaciones correctas. Si tiene preguntas sobre las capacidades o limitaciones de un producto de Morehouse Instrument Company, o para acceder a un manual, póngase en contacto con su representante de ventas o envíe un correo electrónico a info@mhforce.com.

 Svenska

VARNING: Morehouse Instrument Companys produkter är precisionsinstrument för specifika kraft- eller vridmomentkalibreringsapplikationer. Felaktig användning, överskridande av angivna kapaciteter eller obehöriga modifieringar kan leda till allvarliga personskador, dödsfall, maskinskador och upphävande av garantin. Se alltid till att installationen, inriktningen och användningen är korrekt inom angivna gränser. Använd inte skadade eller synligt komprometterade komponenter. Se din produkthandbok för korrekt användning och specifikationer. Om du har frågor om ett Morehouse Instrument Company-produkts kapacitet eller begränsningar, eller för att komma åt en manual, vänligen kontakta din säljrepresentant eller e-posta info@mhforce.com.