

## Product Guide

# Portable Calibrating Machine





## Table of Contents

Description .....	3
Standard Parts .....	4
Standard Reference Load Cell .....	5
Portable Calibrating Machine Models .....	6
Compression Adapters .....	7
Tension Adapter Kit .....	8
Hand-held Force Gauge L-Bracket Adapters .....	10
Weight Hanging Kit for L-Bracket .....	14

## Description

The Morehouse Portable Calibrating Machine (PCM) was designed and manufactured to address issues associated with calibrating small force measurement instruments. The machine is highly versatile in accommodating various configurations to which force measurement instruments are made at lower capacities (under 2,000 lbf).

Using proper adapters, several types of force instruments such as shear-web load cells, S-type load cells, beam load cells, button load cells, ring force gauges, hand-held force gauges, and small dynamometers can be calibrated in a Portable Calibrating Machine. Features of the versatile calibration system are:

- Capable of force calibration in compression and tension.
- Portable design: The machine weighs 32 lbs and is placed in a case with accessories.
- Calibrates force instruments up to 2,000 lbf.
- Exceptional force control capability to reach and maintain target test forces (e.g. 0.01 lbf. using a 1,000 lbf. Morehouse Ultra-Precision Shear Web load cell).
- Safe and confident calibration procedure for small instruments, which lowers the risk of overloading the instruments
- Built-in swiveling coupling nut to accommodate a variety of adapters and instruments
- Compression bearing pad and ball seat adapter are included for calibrating compression-only instruments

When small force instruments are calibrated in large calibrating machines with high capacities, there is a high risk of overloading the unit under test. The Portable Calibrating Machine lowers this risk by giving the user high controllability over the applied force.

This guide describes different Portable Calibrating Machine models and the accessories and adapters available to calibrate various instruments. For detailed information on the machine's operation and maintenance, refer to the Operation and Instruction Manual for the Portable Calibrating Machine, available at [www.mhforce.com](http://www.mhforce.com).

## Standard Parts

Figure 1 illustrates the main components of a Portable Calibrating Machine. All Portable Calibrating Machines are supplied with:

1. Main loading frame and mechanical jack.
2. Standard load cell mounting adapter.
3. Compression bearing pad.
4. Ball seat adapter.
5. Swiveling coupling nut.
6. Case with custom-cut foam.

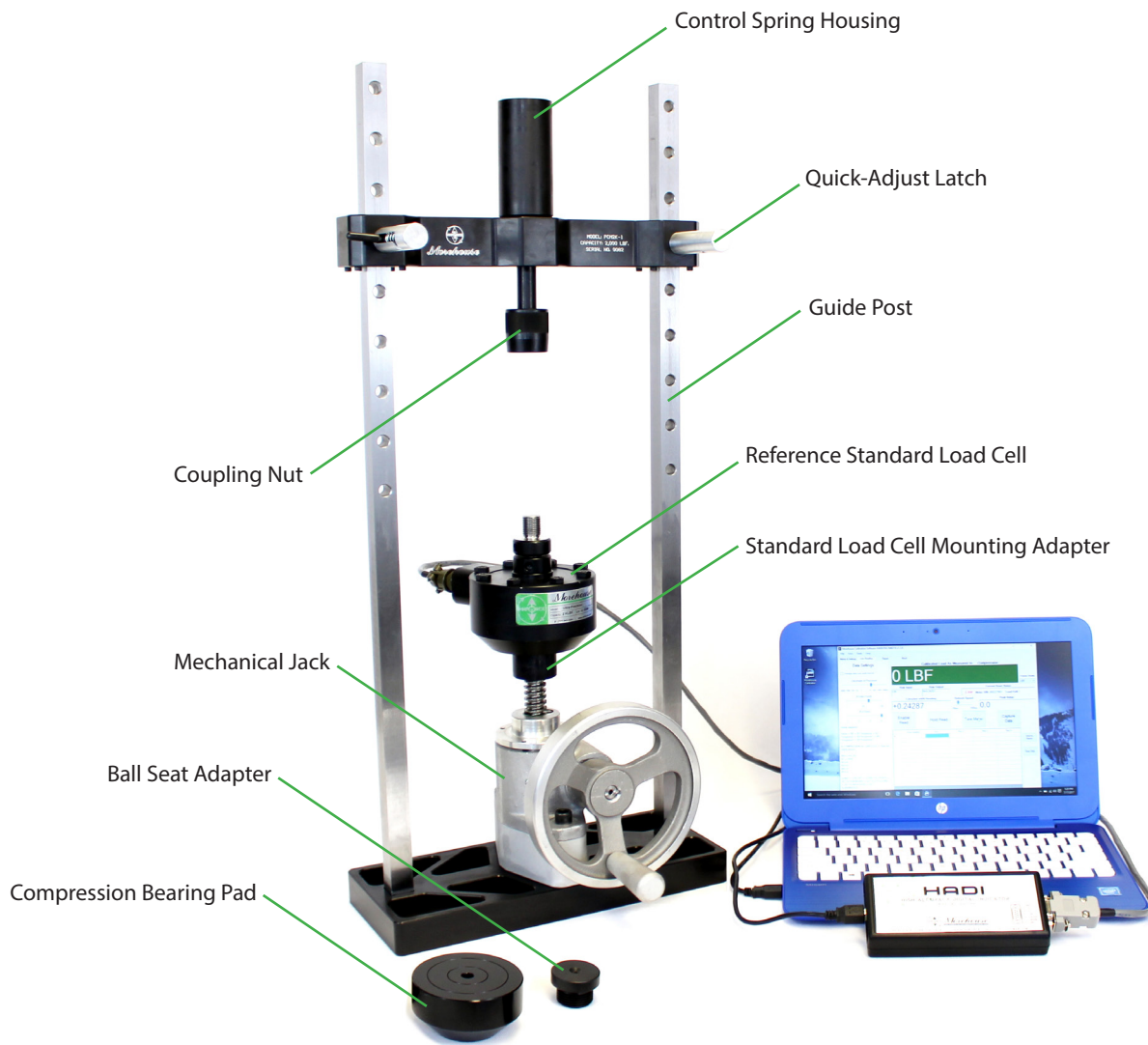

**Figure 1: Components of Portable Calibrating Machine**

## Standard Reference Load Cell

The Portable Calibrating Machine uses a high-accuracy load cell as the reference to measure the applied force to the instrument under test. The reference standard load cell is mounted to the top of the mechanical jack through the standard mounting adapter. The mounting adapter transfers force to the load cell through the bottom shoulder of the load cell and ensures that the standard load cell is loaded in the same manner as it was calibrated.

Morehouse recommends using a Morehouse Ultra-Precision Shear Web load cell as the reference standard in a Portable Calibrating Machine. The standard mounting adapter is designed to mount a Morehouse Shear Web load cell as the reference standard into the Portable Calibrating Machine. However, a custom adapter can install other types of cells in the machine.

The reference standard load cell must be used with a high-accuracy electronic indicator such as the Morehouse 4215 indicator or the High Accuracy Digital Indicator (HADI) to generate a quality calibration standard.



**Figure 2: Ultra-Precision Shear Web Load Cell**



**Figure 3: 4215 Indicator**

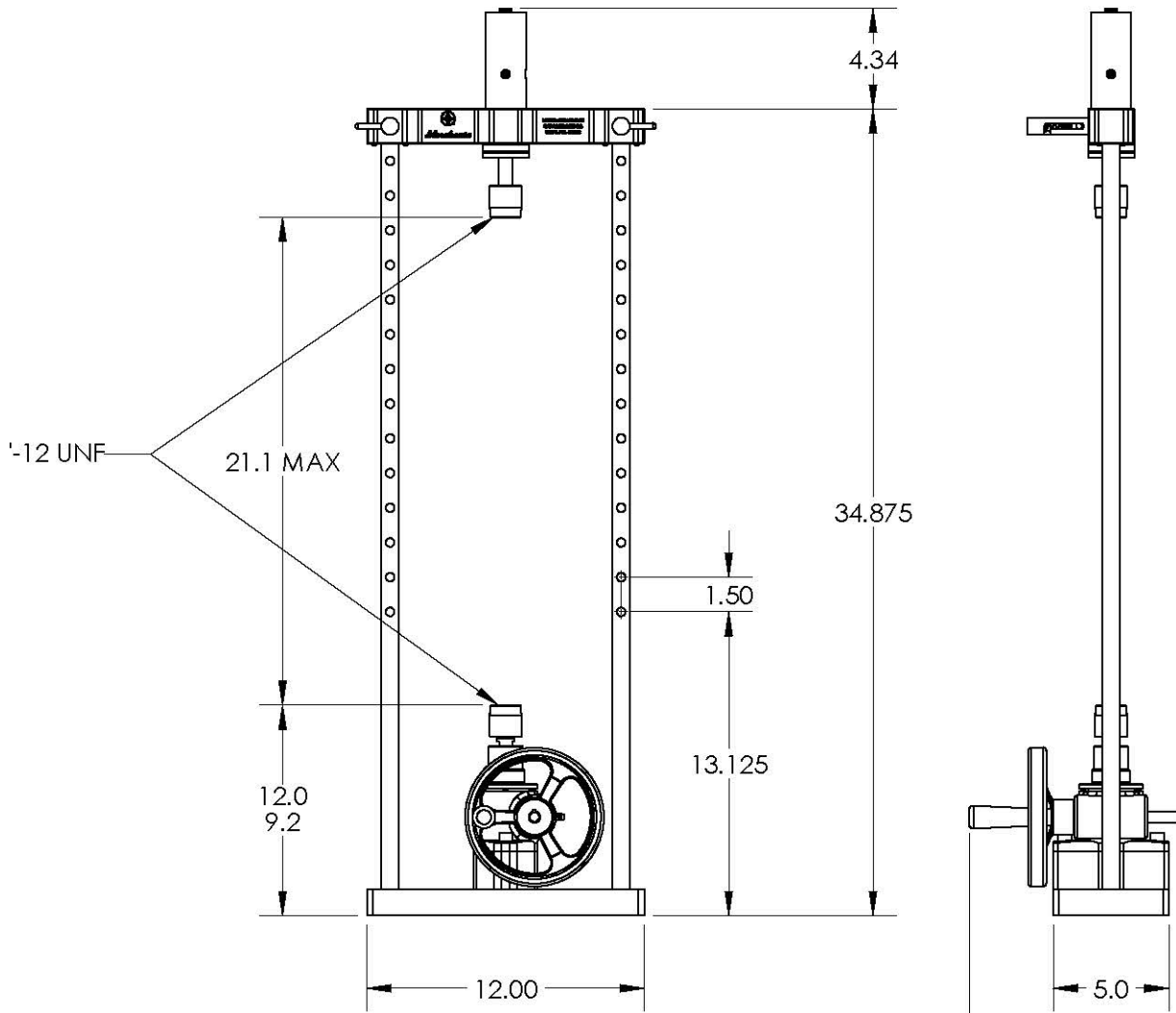

**Figure 4: HADI Indicator**



## Portable Calibrating Machine Models

The Portable Calibrating Machine is offered with two reference load cell mounting threaded adapters for different users' calibration requirements. Figure 5 and Table 1 contain specifications for the standard model. Contact Morehouse if you need additional features or different sizes for the Portable Calibrating Machine.



**Figure 5: Dimension Guide for PCM2K-2 Machine Model**

Model	Swiveling Coupling Nut Thread	Reference Load Cell Mounting Threaded Adapter
PCM2K-2	1.125"-12 UNF	0.625"-18 UNF or 0.250"-28 UNF

**Table 1: Portable Calibrating Machine Standard Model**

## Compression Adapters

Compression calibration adapters are required for compressive force calibration on force transducers in a Portable Calibrating Machine. The set consists of two parts:

- Compression bearing pad.
- Ball seat adapter.

These adapters are included with all Portable Calibrating Machines unless otherwise specified by the user. The compression bearing pad is threaded directly on top of the reference standard load cell. The alignment hole at the center of the compression bearing pad helps align the instrument under test. To use this feature, a set of Morehouse alignment plug adapters must be mounted to the bottom part of the instrument. The alignment plug adapter fits into the alignment hole to ensure that the reference standard load cell and unit under test experience the same loading line. The ball seat adapter is threaded into the swiveling coupling nut and has a ball seat machined on the surface to accommodate load balls or loading studs with a spherical surface.

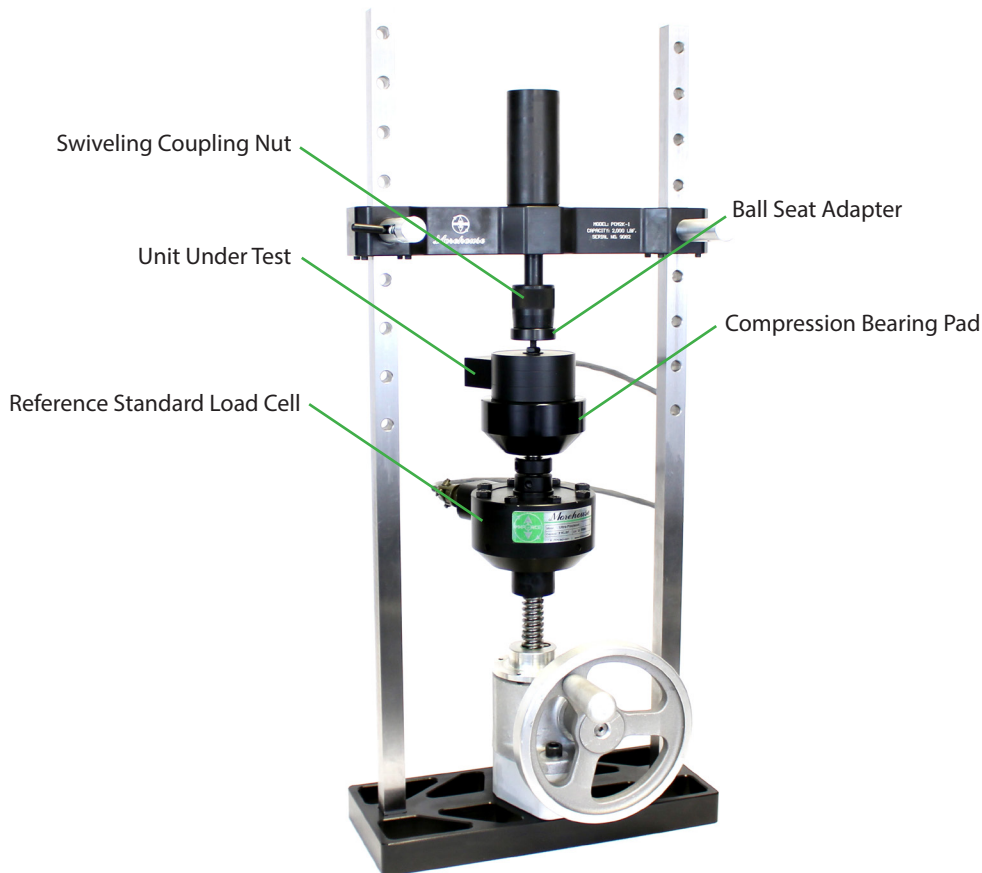

**Figure 6: Calibration Setup with Compression Calibration Adapters**



## Tension Adapter Kit

Tension force calibration often requires proper adapters to install the force instrument into the calibrating machine. Morehouse offers a tension adapter kit for the Portable Calibrating Machine to help with tension force calibration setups.

The kit includes threaded adapters, which mount the unit under test between the reference standard and the stage beam of the Portable Calibrating Machine. Two adapters are typically needed for a tension setup. One adapter mounts the unit under test on top of the reference standard. Another adapter ties the top of the unit under test to the coupling nut of the stage beam. The swiveling action of the coupling nut makes it easy for the user to install the adapters.

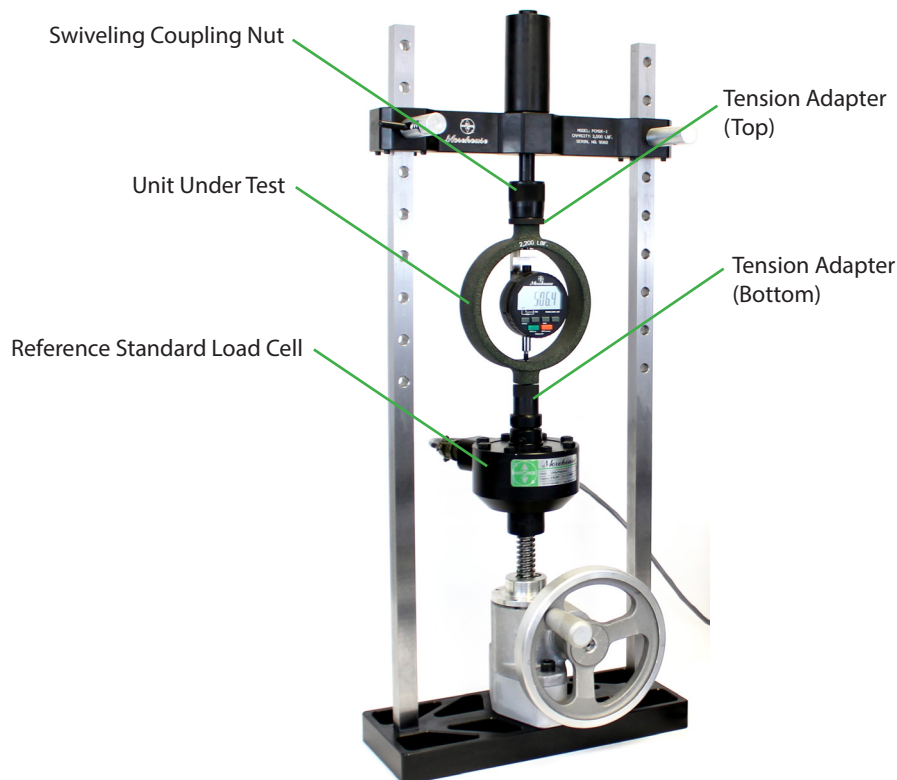

**Figure 7: Tension Setup with the Tension Adapter Kit**



The kit includes the standard thread sizes for most force instruments available within the 2,000 lbf capacity range. Table 2 shows the thread sizes included in the standard Tension Adapter Kit. Morehouse can manufacture other thread sizes per user request. This Tension Adapter Kit is designed to be compatible with Morehouse shear web load cells. If another type of load cell is used as the reference standard in a Portable Calibrating Machine, consult Morehouse before placing an order for this kit.



**Figure 8: Tension Adapter Kit for a Portable Calibrating Machine**

UUT Side Thread	Max Capacity (lbf)	Qty.	Machine Side Thread
0.25-28 UNF-2B	1800	1	0.625-18 UNF-2B to install on Morehouse Shear Web Standard
0.25-28 UNF-2B	1800	1	1.125-12 UNC-2A to install into the swiveling coupling nut
0.500-13 UNC-2B	7000	1	0.625-18 UNF-2B to install on Morehouse Shear Web Standard
0.500-13 UNC-2B	7000	1	1.125-12 UNC-2A to install into the swiveling coupling nut
0.500-20 UNF-2B	8000	1	0.625-18 UNF-2B to install on Morehouse Shear Web Standard
0.500-20 UNF-2B	8000	1	1.125-12 UNC-2A to install into the swiveling coupling nut
0.625-18 UNF-2B	12000	1	0.625-18 UNF-2B to install on Morehouse Shear Web Standard
0.625-18 UNF-2B	12000	1	1.125-12 UNC-2A to install into the swiveling coupling nut
0.25-28 UNF-2A	1800	1	0.625-18 UNF-2B to install on Morehouse Shear Web Standard
0.25-28 UNF-2A	1800	1	1.125-12 UNC-2A to install into the swiveling coupling nut
0.500-13 UNC-2A	7000	1	0.625-18 UNF-2B to install on Morehouse Shear Web Standard
0.500-13 UNC-2A	7000	1	1.125-12 UNC-2A to install into the swiveling coupling nut
0.500-20 UNF-2A	8000	1	0.625-18 UNF-2B to install on Morehouse Shear Web Standard
0.500-20 UNF-2A	8000	1	1.125-12 UNC-2A to install into the swiveling coupling nut
0.625-18 UNF-2A	12000	1	0.625-18 UNF-2B to install on Morehouse Shear Web Standard
0.625-18 UNF-2A	12000	1	1.125-12 UNC-2A to install into the swiveling coupling nut

**Table 2: Tension Adapter Kit Components**

## Hand-held Force Gauge L-Bracket Adapters

Calibrating hand-held force gauges in regular calibrating machines can be cumbersome and involves a risk of overloading the gauge. Hand-held force gauges are commonly manufactured for measuring small forces, which are difficult to generate and maintain in a large force calibrating machine. A sudden increment in the applied force can overload the instrument under test and reference standards. Such incidents can be costly, creating long downtimes. The Portable Calibrating Machine addresses this issue by providing highly precise force control and eliminating sudden increments in applied force.

Morehouse offers a set of L-Bracket adapters to calibrate hand-held force gauges in a Portable Calibrating Machine. The L-Brackets consist of several back plates, bottom plates, and threaded adapters to mount various models of hand-held force gauges. Each back plate can be mounted to any bottom plate for different combinations. Each backplate is designed with special hole patterns to accommodate various types of hand-held force gauges.

The force gauge is mounted to the back plate through the hole pattern, and the back plate is directly mounted to the bottom plate. Bottom plates have a threaded hole at the center with 0.625"-18 UNF-2B thread, which is used to install the L-Bracket and hand-held force gauge assembly directly to the reference standard load cell in a Portable Calibrating Machine. Bottom plates are included with various mounting hole offsets from the edge. Based on the type of hand-held force gauge, the proper bottom plate must be used to ensure the line of applying force in the calibration setup aligns with the force gauge's load line. A threaded adapter is utilized to attach the loading rod of the hand-held force gauge to the coupling nut in a Portable Calibrating Machine.

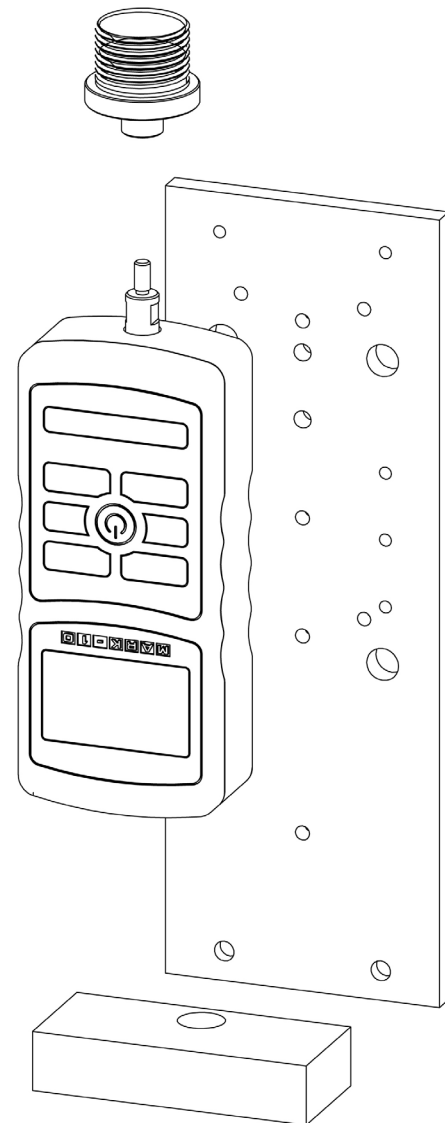

**Figure 9: Calibration Setup for a Hand-held Digital Force Gauge Using an L-Bracket**



This L-Bracket set can be used to calibrate several hand-held force gauge models. A combination of a back plate, base plate, and threaded adapter must be assembled for each model. Table 3 lists the hand-held force gauge models that can be calibrated using the L-Bracket adapters set in a Portable Calibrating Machine. It also provides information to assist with selecting the appropriate parts of the adapter kit for calibrating each force gauge model. If you need to calibrate hand-held force gauges not shown in Table 3, contact Morehouse to add the necessary pieces to your kit.

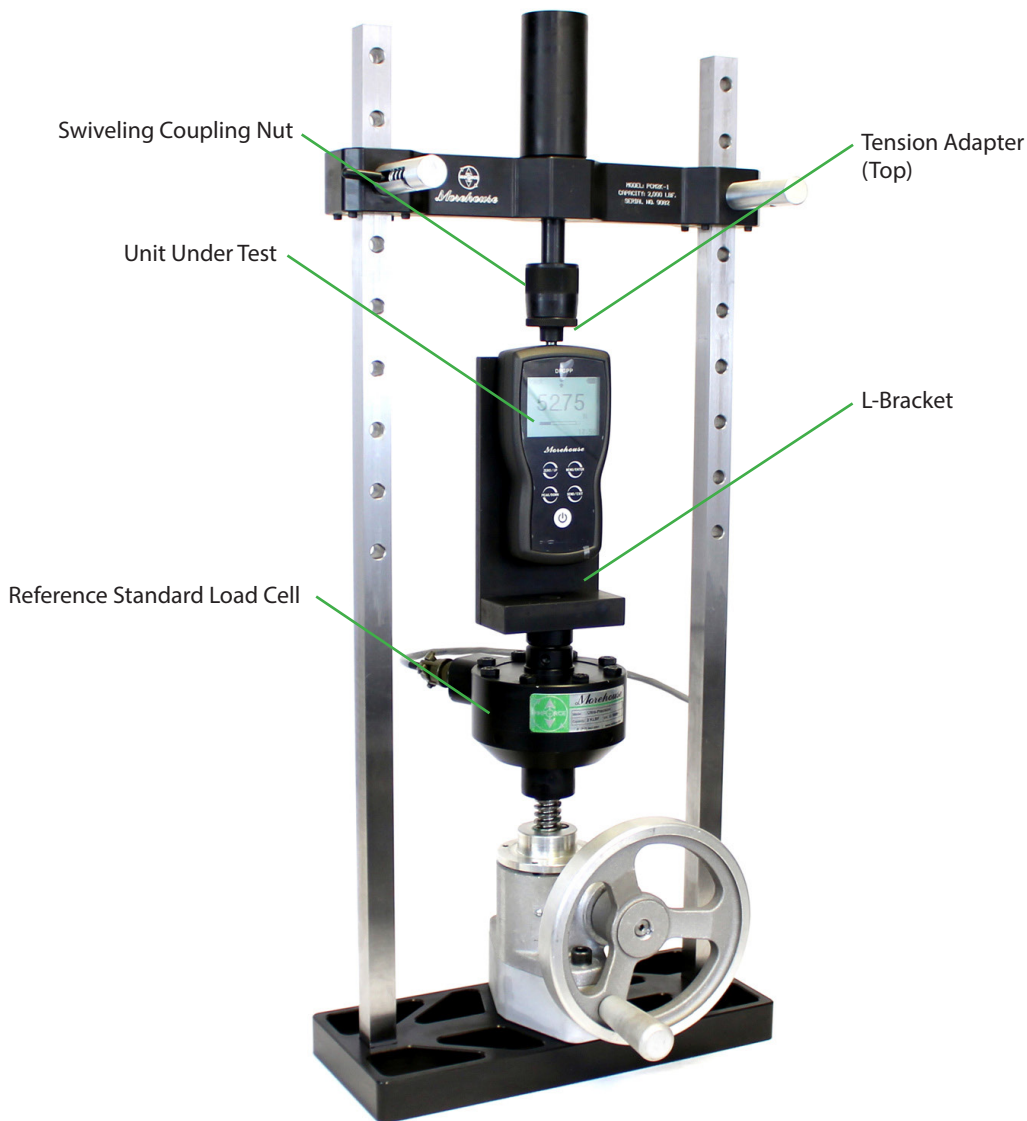

**Figure 10: Calibration Setup for a Hand-held Force Gauge with a L-Bracket**

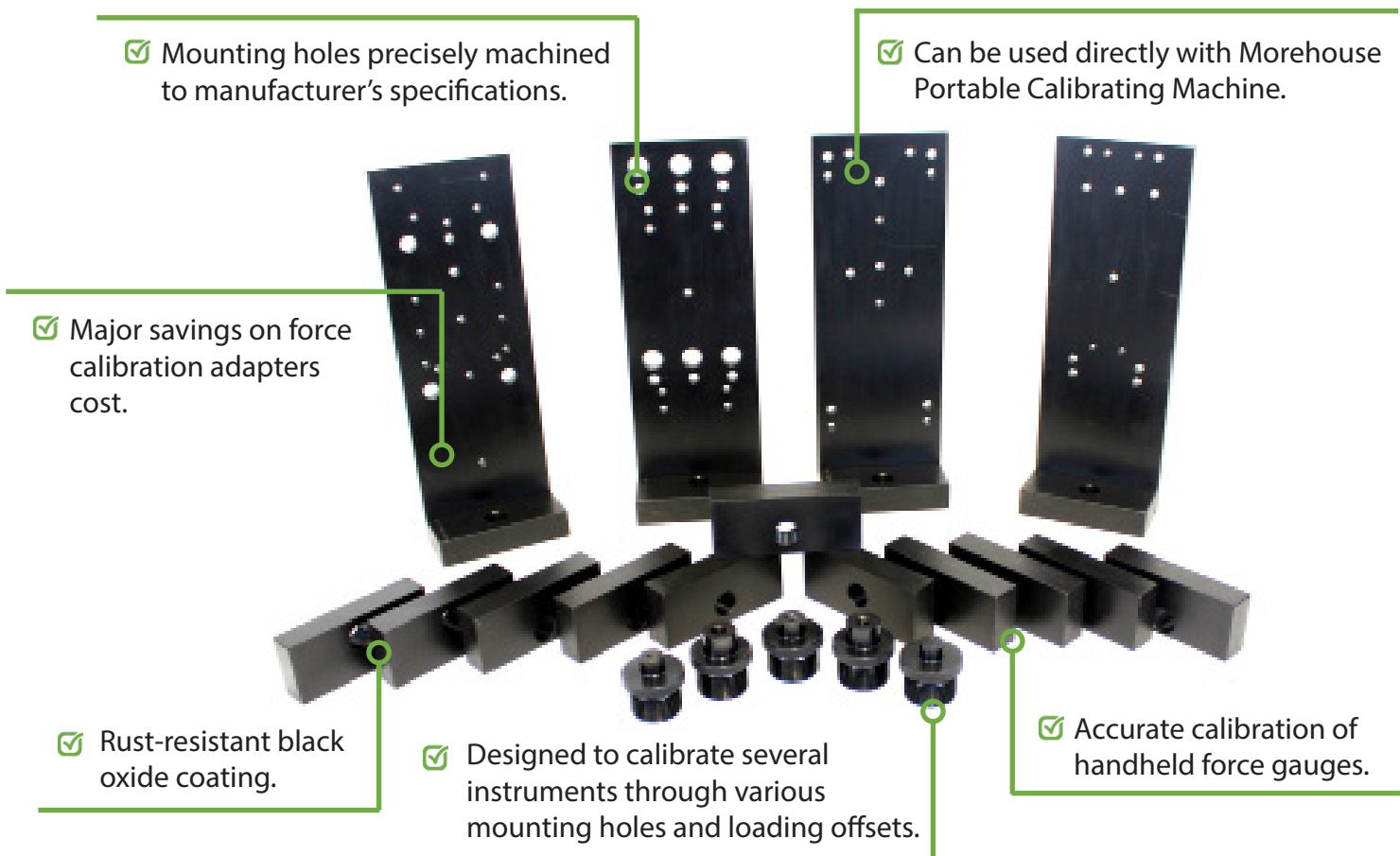

**Figure 12: L-Bracket Adapters Kit for Hand-held Force Gauges**

## Standard Features

- » Capable of calibrating several hand-held force gauges from different manufacturers.
- » Kit includes several back and base plates which can be combined to calibrate various instruments.
- » Can be used with Morehouse Portable Calibrating Machine or Universal Calibrating Machines.
- » Precision machining of mounting hole patterns and loading offsets ensures accurate calibration.
- » Versatile kit is expandable and reduces calibration lead time.
- » Significant savings on the long-term cost of hand-held force gauge calibration adapters.
- » Rust-resistant black oxide coating on all parts.

**Table 3: Hand-held Force Gauges that can be Calibrated with a L-Bracket (next page)**



Manufacturer	Model	L-Bracket Back-Plate	L-Bracket Base Plate Part No.	Threaded Adapter
MOREHOUSE	DFGPP	A	CL-1B-0.5433	M6
AMETEK	D	D	CL-1B-1.1875	#10-32 OR 5/16-18
AMETEK	DFX SERIES	C	CL-1B-0.6850	#10-32 OR 5/16-18
AMETEK	AMETEK III (< 100 LBF)	A	CL-1B-0.7500	#10-32
AMETEK	AMETEK III (> 100 LBF)	D	CL-1B-1.1875	5/16-18
AMETEK	SERIES L	A	CL-1B-0.7812	#10-32
AMETEK	ACCUFORCE CADET SERIES ML	A	CL-1B-0.7812	#10-32 OR 5/16-18
AMETEK	ACCUFORCE III (250 GRAMS / 100 LBS)	A	CL-1B-0.7812	#10-32
AMETEK	ACCUFORCE III (250 LBS / 500 LBS)	D	CL-1B-1.1875	5/16-18
CHATILLON	DFM	B1	CL-1B-0.5000	#10-32
CHATILLON	DFGRS LIGHT DUTY	B1	CL-1B-0.5000	#10-32
CHATILLON	DFGRS HEAVY DUTY	B1	CL-1B-0.5625	5/16-18
CHATILLON	DGGRS	B1	CL-1B-0.5000	#10-32
CHATILLON	DFIS	B1	CL-1B-0.5625	#10-32
CHATILLON	DPPH	B1	CL-1B-0.5625	5/16-18
CHATILLON	DFE	C	CL-1B-0.6850	#10-32 OR 5/16-18
CHATILLON	DFGS	C	CL-1B-0.6850	#10-32
CHATILLON	DPP	C	CL-1B-0.6850	#10-32
CHATILLON	DFX	C	CL-1B-0.6850	#10-32 OR 5/16-18
CHATILLON	DG	D	CL-1B-1.0000	5/16-18
CHATILLON	LG	C	CL-1B-0.6850	#10-32
IMADA	DPS	A	CL-1B-0.4700	#10-32 OR M6
IMADA	DS2	A	CL-1B-0.4700	#10-32 OR M6
IMADA	DST	A	CL-1B-0.4700	#10-32 OR M6
IMADA	ZP	A	CL-1B-0.4700	#10-32 OR M6
IMADA	PS	C	CL-1B-0.6850	#10-32 OR M6
IMADA	FB	C	CL-1B-0.6850	#10-32 OR M6
IMADA	MF	C	CL-1B-0.6850	#10-32 OR M6
IMADA	Z2H-1100	A	CL-1B-0.8500	M10
IMADA	ESH	A	CL-1B-0.9800	M10
IMADA	ZTS/ZTA LOW CAP. (<=220 LBF)	A	CL-1B-0.4700	#10-32 OR M6
IMADA	ZTS/ZTA HIGH CAP. (550 & 1100 LBF)	A	CL-1B-0.9800	M10
MARK 10	BG	A	CL-1B-0.4200	#10-32 OR 5/16-18
MARK 10	EG	A	CL-1B-0.4200	#10-32 OR 5/16-18
MARK 10	MG	A	CL-1B-0.4200	#10-32 OR 5/16-18
MARK 10	SERIES 5 (<= 500 LBF)	A	CL-1B-0.4200	#10-32 OR 5/16-18
SHIMPO	FGE	A	CL-1B-0.5000	M4 OR M6
SHIMPO	FGV	A	CL-1B-0.5000	M4 OR M6
SHIMPO	MF	C	CL-1B-0.7500	M6
SHIMPO	FGV-500/1000HXY	B1	CL-1B-0.9252	M10

## Weight Hanging Kit for L-Bracket

Morehouse has an optional add-on for the L-Bracket kit that allows users to apply minimal forces to handheld force gauges with small hand weights. As depicted in Figure 9, the weight-hanging apparatus can be added to the L-Bracket and force gauge assembly to apply the hand-weight forces. The final assembly is mounted on the Portable Calibrating Machine. To use the total working space of the machine, the control spring housing of the calibrating machine should be removed, and the L-Bracket should be mounted to the stage beam using the hardware included in the kit. The weight hanging apparatus is made of lightweight material to minimize the tare weight on the unit under test. Figure 10 illustrates the assembly of the weight-hanging kit.

The weight hanging kit is designed as an add-on to the L-Bracket kit and cannot be used for calibration without the L-Brackets.



**Figure 9: Hand-Weight Hanging Kit  
for L-Brackets**

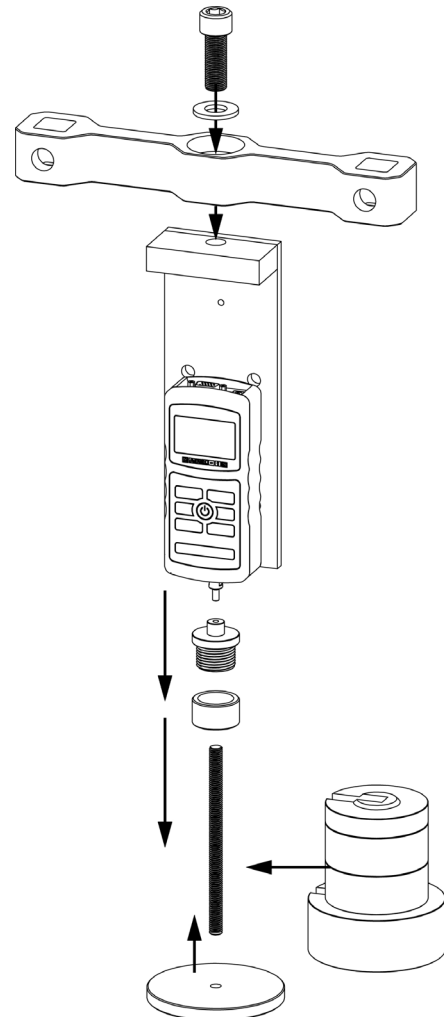

**Figure 10: Weight Hanging Kit  
Assembly with L-Bracket**