

Operation and Instruction Manual

Digital Ring Force Gauge



Table of Contents

Safety	3
Introduction	4
Preparation for Loading	5-6
Operation Instructions	6-10
Compression and Tension Setup	7
Indicator Operation	8-10
Changing Indicator Battery	10
Calibration	11-12
Calibration Procedure	11
Resolution	11
Frequency of Calibration	12
Maintenance	13
Upgrade from Analog Ring Force Gauge	13
Temperature Correction for Digital Ring Force Gauges	14-15
Fahrenheit Scale (Drawing 99332)	14
Centigrade Scale (Drawing 99332-1)	15

Safety

Refer to the Morehouse Force Measurement Equipment Safety guide PG-9000 for general guidelines about force calibration safety. Safety practices must be followed when using a Digital Ring Force Gauge.

- Read the instruction manual carefully and ensure that anyone who intends to operate the machine has proper training on safe practices of using a portable calibrator.
- Inspect all components of the Digital Ring Force Gauge and any components used from a connection before use to ensure all parts are free of defects and are attached properly.
- Digital Ring Force Gauges can only be used under their rated capacity. Overloading one may cause a dangerous situation for the user and permanently damage the instrument.
- To avoid situations that may cause personal injuries, wear eye protection when using a Morehouse Digital Ring Force Gauge or any other force-measuring instrument.
- Any adapter or accessory you design, make, or purchase with a portable calibrator or force-measuring instrument must be of proper design and made from steel of the proper strength to withstand the forces to which it is subjected. It is most important that adapters and accessories be test-loaded under safe conditions before actual use with an instrument. Equipment should not be used beyond its maximum rated capacity. Failure to use the proper strength material may result in serious injury or death.

Applying forces to equipment and instruments is inherently dangerous. This document does not, and cannot, foresee all safety considerations in your testing and application environments. It is important to give careful consideration to any application of force.

Introduction

The Digital Ring Force Gauge is relatively simple to operate. If maximum accuracy is desired, the Digital Ring Force Gauge should be placed near where it is to be used and allowed to stabilize at the ambient temperature that will prevail during use. Deviations from the temperature at which the Digital Ring Force Gauge was calibrated will cause errors of approximately 1% for every 70 degrees F.

A Digital Ring Force Gauge is a load ring that deflects under compressive or tensile forces. The deflection of the ring is continuously measured by a digital indicator mounted inside the ring. The Morehouse primary force calibration laboratory programs the indicator and interprets the deflection values to direct calibrated force values displayed on the digital screen.

The indicator displays the force in the engineering units specified by the user at purchase. The operator will not need an additional electronic indicator to read the sensor output and does not need an interpretation table to convert and interpolate readings to calibrated force values.

Typically, the instrument's capacity is engraved on the front side of the ring, and the indicator is set to display force in the same units used to express the instrument's capacity.

A standard Digital Ring Force Gauge includes the components shown below:



Figure 1: Digital Force Gauge Standard Components

Preparation for Loading

Compression

If the Digital Ring Force Gauge is to be loaded against the spherical surface on the top boss, then a piece of cold rolled steel (loading pad) should be inserted between the top boss or button and the upper surface against which it will bear. This will prevent the button from causing an indentation in the upper surface. Following is a list of recommended sizes for the cold rolled steel to be used:

- Capacities through 50,000 lbf – 2" x 2" x 0.5" Thick
- Capacities 50,001 through 100,000 lbf – 3" x 3" x 0.5" Thick
- Capacities 100,001 through 200,000 lbf – 4" x 4" x 0.75" Thick
- Capacities 200,001 through 500,000 lbf – 4" x 4" x 1.5" Thick
- Capacities 500,001 through 1,000,000 lbf – 5" x 5" x 2.0" Thick

The surface on which the lower boss will bear should be flat to minimize non-axial loading. If the Ring Force Gauge is to be loaded using a load ball in place of the spherical surface on the top boss, then the surfaces opposing the ball should have a ball seat approximating the dimensions shown in Figure 1. When loading through a steel ball, be certain that it is made of hardened chrome alloy steel and that it is the recommended size to withstand the force applied. Never use a carbide ball because carbide is brittle and will shatter under load.

Tension

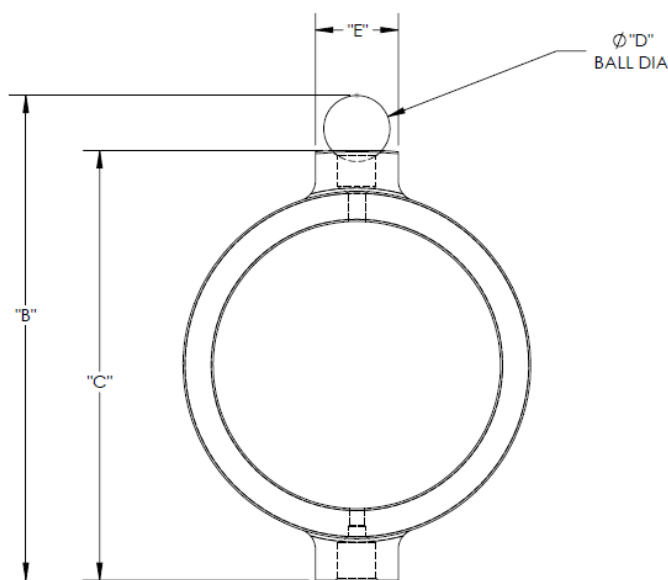

Capacity (lbf)	A Dia.	B	C	D Dia.	E Sq
50	0.75	6.80	6.00	0.88	0.75
100	0.75	6.80	6.00	0.88	0.75
200	0.75	6.80	6.00	0.88	0.75
500	0.75	6.80	6.00	0.88	0.75
1,000	0.75	6.80	6.00	0.88	0.75
2,000	0.75	6.80	6.00	0.88	0.75
5,000	0.88	7.38	6.50	1.00	1.25
10,000	0.88	7.38	6.50	1.00	1.25
20,000	0.88	7.88	7.00	1.00	1.25
50,000	0.88	10.38	9.50	1.00	1.75
100,000	0.88	11.88	11.00	1.00	2.50

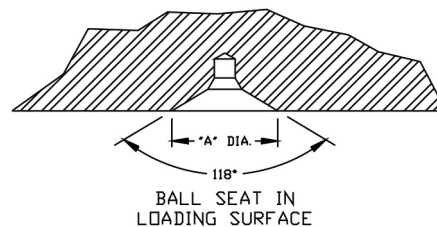

Figure 2: Ball Seat Dimensions

When mounting a tension type Digital Ring Force Gauge keep any special attachments or adaptors in as close alignment as possible.

Operation

After mounting the Digital Ring Force Gauge in the press or other assembly in which the mechanical forces are to be measured, the force gauge should be exercised two or three times to stabilize it. Load the Digital Ring Force Gauge to its capacity or the force to which it is to be used, whichever is lower, and release it.

The versatile ring force gauge can be used in many ways, and the applications are limitless. It is supplied with tapped holes in external bosses, so it can be easily fitted with special adaptors, accessories, or mounting brackets of base plates that are incorporated into an application. Please contact us if you have any questions about how the Digital Ring Force Gauges can be used or about adapters you may need.

The dial indicator used to measure the ring's deflection is accurate to 0.001 mm and provides high stability over time. The indicator is programmed during calibration and adjusted to convert ring deflection values to force in the units specified by the user at the time of purchase. The indicator also provides a number of useful measurement features, which are explained in the operation section of this manual.

Compression and Tension Setup

Model FRC

Designed and calibrated to measure compressive forces only

Capacity	Setup
Lower than or equal to 2,500 lbf	A base adapter is threaded into the lower boss of the force gauge to provide stability.
	A load button is threaded into the upper boss to help with load line alignment.
Higher than 2,500 lbf	Larger bosses keep the force gauge stable. The upper boss has a spherical surface which can be loaded against directly.
	A chamfer in the upper boss can accommodate a load ball. A load ball is recommended to help with better load line alignment.

Model FRT

Designed and calibrated to measure tension forces only

Capacity	Setup
Lower than or equal to 10,000 lbf	A set of two rod ends can be used to measure tensile forces and help with tensile load line alignment.
Higher than 10,000 lbf	Threaded upper and lower bosses for special adapters. Typically, gauges in this capacity range are used for special high force measurement applications and need special adapters for their application. Morehouse can help users find safe and reliable solutions for their specific application.

Other adapters can be used to generate tensile loading setups. Prior to using any tension adapters, the operator must ensure the adapters are rated for the force that will be applied to the instrument during the force measurement process. Morehouse manufactures a large variety of tension adapters which can be used with Digital Ring Force Gauges to produce tension force calibration setups for almost any application.

Indicator Operation

The Digital Ring Force Gauge's indicator features built-in functions that can assist with special force applications. The following instructions can be used to activate these functions or switch to different modes. All the indicator operations are performed through the small keypad on the indicator. Figure 3 demonstrates the layout of the indicator keypad.

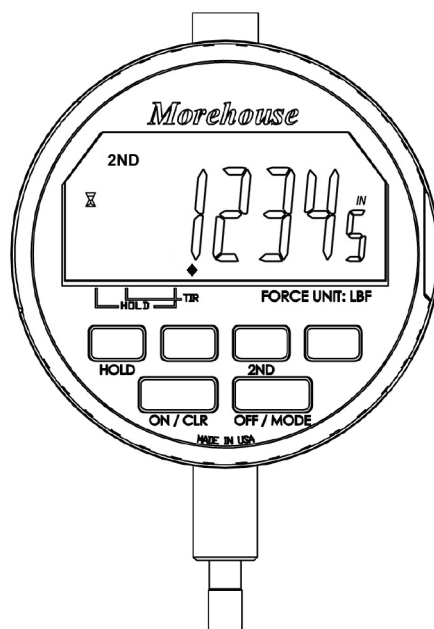

Figure 3: Layout of the Indicator Keypad

Power On/Off

To turn the unit on, press and hold ON/CLR until indicator turns on. To turn off, press OFF/MODE.

Reset Display

Pushing the ON/CLR button on the indicator Clears/resets display to '0' or spindle position.

Auto-Off Toggle

To turn the Auto-Off function on or off, press the 2ND button (2ND icon should appear on the display). Press the OFF/MODE. An hour glass appears at the left side of the display if AUTO OFF is active. If AUTO OFF is active the indicator will power off in 10 minutes with no activity (button press or spindle movement).

Hold Mode

The Hold Mode allows the user to hold the value on the display according to the specified mode. Press HOLD to toggle hold mode on and off.

MAX (Compression Max Hold)

Holds and displays the highest reading attained. When the Digital Ring Force Gauge is in compression, the indicator displays a positive value, and when the MAX HOLD is on, the highest compressive force is displayed. When the Digital Ring Force Gauge is under tension, the indicator displays a negative number, and when MAX HOLD is on, the minimum tensile force is displayed.

MIN (Tension Max Hold)

Holds and displays the lowest reading attained. When the Digital Force Gauge is in compression, the indicator displays a positive value, and when the MIN HOLD is on, the lowest compressive force is displayed. When the Digital Force Gauge is under tension, the indicator displays a negative number, and when MIN HOLD is on, the maximum tensile force is displayed.

FRZ

Holds and displays the reading displayed when the HOLD button is pressed.

To select the type of HOLD (MAX, MIN, FRZ), press HOLD continuously until the desired feature is flashing on the display, then release HOLD. Note that pressing the ON/CLR button resets the indicator to the spindle position except in FRZ; it resets to zero.

TIR Mode

Total Indicator Runout (TIR) mode ignores loading mode (compression or tension) and instead measures the difference between peak and valley (MAX and MIN) values. Additionally, in this mode, the maximum and minimum values for the entire loading period are stored in the memory and can be retrieved. To enter TIR Mode, continuously press the OFF/MODE button until the diamond icon appears above the TIR function. The Freeze (FRZ) is the only hold function in TIR mode. Use the HOLD button to view the Peak (MAX) Value or the Valley (MIN) Value. Press the HOLD button down until the MIN or MAX is displayed. The difference between the MIN and MAX Values equals the TIR Value. It should be noted that the gauge displays the numerical difference between the highest and lowest values. In contrast, compressive forces are displayed in positive numbers, and tensile forces in negative numbers.

NOTE: Press and hold the OFF/MODE button to change the indicator's measurement mode. While this button is pressed down, the indicator switches between modes continuously, and a triangle or diamond flashes at the lower section of the screen for each mode. To put the indicator in normal mode, press and hold the OFF/MODE button until the triangle on the right-hand side flashes, then release the OFF/MODE button. The triangle in the middle indicates Absolut (ABS) mode and the diamond on the left-hand side indicates TIR mode.

Changing Indicator Battery

The indicator used in the Digital Ring Force Gauge uses two IEC standard lithium batteries, type CR2450N. The Digital Ring Force Gauge is shipped with the batteries installed. Note that the indicator has an AUTO-OFF feature to conserve battery life. After 10 minutes of no activity (no key presses or spindle movement), the gauge will turn itself off. This feature may be disabled if continuous operation is desired; see AUTO-OFF On/Off instructions in this manual.

To install new batteries, the indicator must be removed from the ring. Calibration is recommended after this procedure. If batteries need to be changed frequently, it is recommended to get the power cable to power the indicator from an AC outlet.

Before removing the indicator, ensure no force is applied to the force gauge. Remove the indicator from the bracket. Using a narrow screwdriver, gently pry under the tab on the left side of the plastic bezel and slide out the battery tray. Remove the batteries and insert the new batteries, “+” side up, into the tray cavities. Then slide the tray back into its bezel slot, taking care that the batteries stay in proper position. Figure 4 illustrates the position of the battery compartment on the indicator. Replace the indicator, ensuring that the indicator is mounted back on the bracket at the middle of its full range while the force gauge is not under any load. To determine the middle of the range, before putting the indicator back in the force gauge, zero the indicator and then push the moving stem all the way in. Note the number displayed at full range and mount the indicator on the bracket at a position that reads half of the full range.

Battery compartment in open position for changing the battery

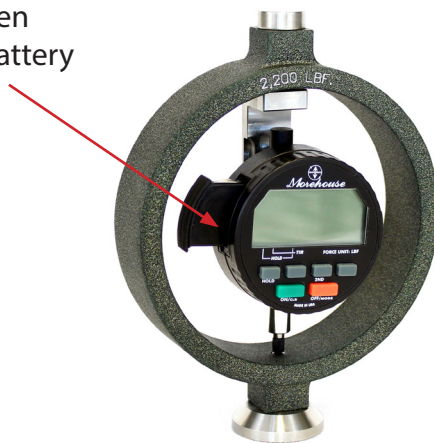

Figure 4: Battery Compartment in Morehouse Digital Force Gauges

Calibration

Calibration Procedure

Morehouse uses deadweight force calibrating systems to calibrate Digital Ring Force Gauges up to 120,000 lbf in both compression and tension modes. For higher capacities, secondary force standards are used, which are calibrated directly by the National Institute of Standards and Technology (NIST).

First, the gauge deflection is measured under different forces during calibration to adjust the Digital Ring Force Gauge indicator for reading direct force values. Then, the deflection information measured by the indicator is converted to direct force values in the engineering units specified by the user at the time of purchase through the firmware and program built into the indicator.

Morehouse uses 10 to 12 points to adjust the indicator for a direct read. In other words, the Digital Ring Force Gauge is calibrated at 10-12 individual points, and the contributing force values are input into the indicator. For the force values between the calibrated points, the indicator's internal program performs an interpolation procedure for each individual segment. This calibration procedure diminishes the system's nonlinearity to a large extent compared to a two-point single-line calibration.

Resolution

Digital Ring Force Gauges measure the applied force by measuring the deflection of the ring under force and converting the deflection values to force readings. All Digital Ring Force Gauges are designed and manufactured to deflect around 0.030 in. (762 μm) under capacity force. Additionally, the indicator used in the Digital Ring Force Gauges has a resolution of 1 μm . Therefore, the force resolution of the instrument is calculated internally by the digital indicator by dividing the force at capacity by the total deflection of the force gauge at capacity in microns. For example, if a 2,000 lbf force gauge deflects 0.30 in. (762 microns) at capacity, the resolution and readability of the instrument will be:

$$2,000 \div 762 = 2.62 \text{ LBF}$$

The deflection of each gauge could be slightly different from that of other gauges with the same capacity. In all cases, the indicator automatically converts deflection to force values, and the user does not have to make any adjustments.

Each Morehouse Digital Force Gauge is designed to operate under a specified force capacity. The user must ensure the force gauge is not put under forces higher than its rated capacity. Overloading a force gauge may result in permanent deformation of the ring and irreversible damage to the instrument. Additionally, any deformation in the ring will void the instrument's calibration. If any suspicion is raised on whether a Digital Force Gauge has been overloaded, the user must verify the validity of the instrument calibration through proper force calibration procedures.

Frequency of Calibration

The question, “How often should a Digital Ring Force Gauge be calibrated?” is difficult to answer. Some specifications require gauges used to check or calibrate production; general inspection devices and gauges should be recalibrated annually or biannually. However, where there is no particular specification that must be complied with, the following general rules may be used as a guide to determine the frequency of calibration:

1. When the Digital Ring Force Gauge is used daily under conditions where it may be subjected to vibration and dirt and grit infiltration, and the utmost accuracy within its limits is desired, semi-annual recalibration is suggested. Annual or biannual recalibration is suggested if the force gauge is not subjected to possible infiltration or contamination under the above conditions, or the highest possible degree of accuracy is not required.
2. If the Digital Ring Force Gauge is used two or three times a week to make general force measurements to the highest possible degree of accuracy, within its limits, annual recalibration is suggested.
3. If the Digital Ring Force Gauge is used four or five times a month to check or calibrate another force measuring device or machine such as presses, testing machines, load cells, etc., bi-annual calibration is suggested.

Maintenance

Each Morehouse Digital Ring Force Gauge is designed to operate under a specified force capacity. The operator must ensure the force gauge is not put under forces higher than its rated capacity. Overloading a force gauge may result in permanent deformation of the ring and irreversible damage to the instrument. Additionally, any deformation in the ring will void the instrument's calibration. If any suspicion is raised on whether a Digital Ring Force Gauge has been overloaded, the user must verify the validity of the instrument calibration through proper force calibration procedures.

The indicator used in a Digital Ring Force Gauge provides high accuracy and precision in measuring the ring's deflection. The indicator must be well maintained and protected from any impacts to maintain high accuracy between calibration cycles.

The indicator is attached to the ring through a bracket mounted behind the load ring. Check the connection between the indicator and gauge regularly to ensure the indicator is installed firmly to the load ring. Morehouse suggests that the indicator must not be removed from the load ring in between calibration cycles.

If the indicator was removed for any reason, ensure that the indicator is mounted back on the bracket at the middle of its full range once the force gauge is not under any load. To determine the middle range, zero the indicator and then push the moving stem all the way in. Note the number displayed at full range and use it to find the middle of the range when mounting the indicator on the bracket again.

Morehouse includes a protective carrying case with custom-cut foam with each Digital Ring Force Gauge. This case can be for storage of the force gauge on the shelf to avoid impacts to the instrument.

Upgrade from Analog Ring Force Gauge

A standard analog Morehouse Ring Force Gauge can be upgraded to the Digital Ring Force Gauge. With this upgrade, the operator gets a higher accuracy device, as well as other benefits that come from a digital direct read system. For this upgrade, the analog Ring Force Gauge must be sent to the Morehouse facility for installation of the new parts. After the upgrade, all gauges will need to be recalibrated to adjust to the new digital indicator. Contact Morehouse for any additional information or questions about upgrading your analog Ring Force Gauge.



Temperature Correction for Digital Ring Force Gauges

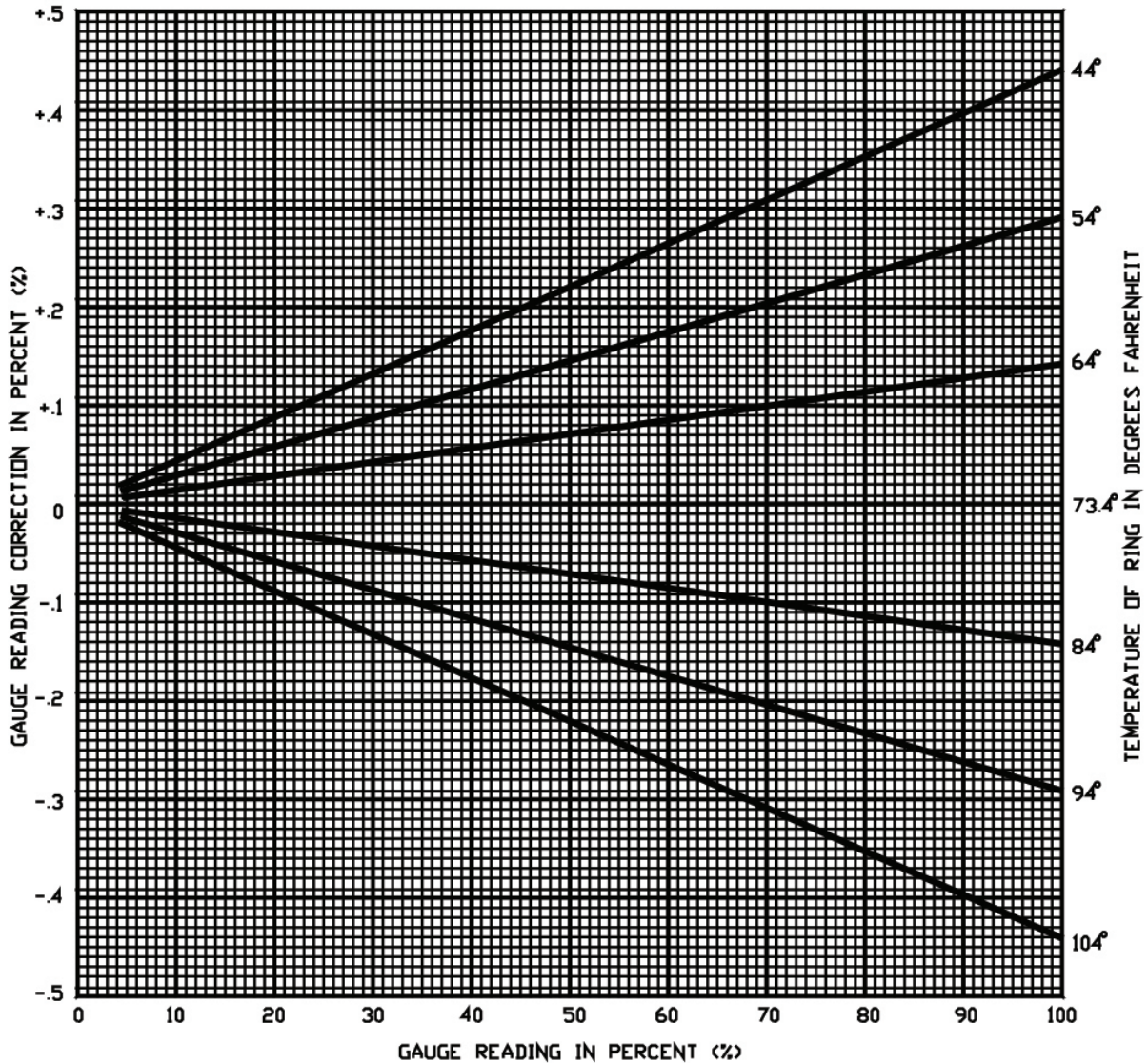

Figure 5: Temperature Correction for Fahrenheit Scale (Drawing 99332)

Temperature corrections may be made using the above graph or by using the following formula

$$D_{73.4} = D_T (1 - .00015(T - 73.4))$$

$D_{73.4}$ = Gauge reading at a temperature of 73.4° Fahrenheit

D_T = Gauge reading at a temperature of T° Fahrenheit

T = Temperature of ring in degrees Fahrenheit

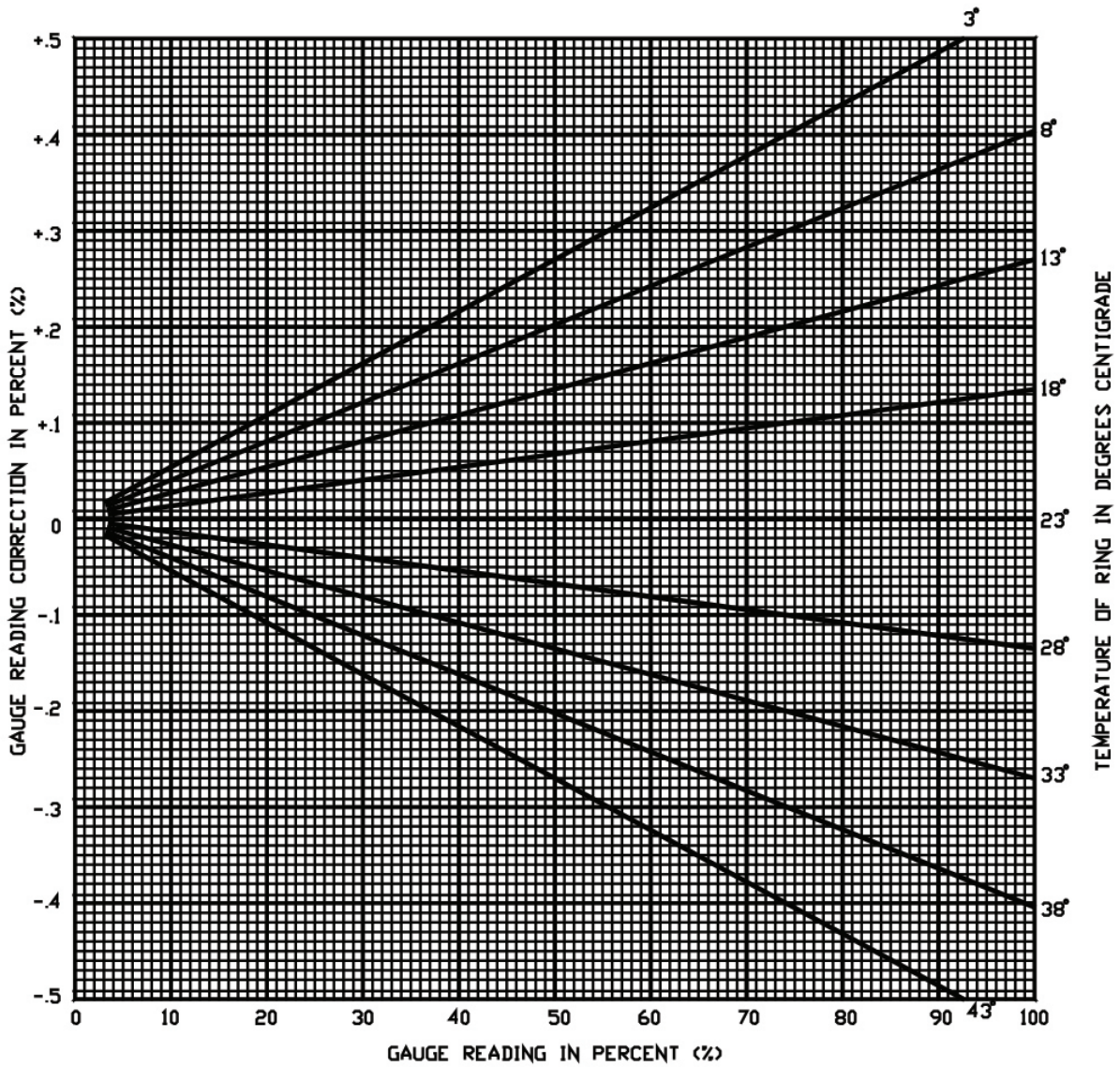

Figure 6: Temperature Correction for Centigrade Scale (Drawing 99332-1)

Temperature corrections may be made using the above graph or by using the following formula

$$D_{23} = D_T (1 - .00027(T - 23))$$

D_{23} = Gauge reading at a temperature of 23° Centigrade

D_T = Gauge reading at a temperature of T° Centigrade

T = Temperature of ring in degrees Centigrade

 **WARNING:** Morehouse Instrument Company products are precision instruments for specific force or torque calibration applications. Improper use, exceeding stated capacities, or unauthorized modifications can result in severe injury, death, machine damage, and warranty voiding. Always ensure proper installation, alignment, and use within specified limits. Do not use damaged or visibly compromised components. Refer to your product manual for proper use and specifications. If you have questions about a Morehouse Instrument Company product's capabilities or limitations or to access a manual, please contact your sales representative or email info@mhforce.com.

 **Dansk**

ADVARSEL: Morehouse Instrument Company produkter er præcisionsinstrumenter til specifikke kraft- eller momentkalibreringsapplikationer. Forkert brug, overskridelse af angivne kapaciteter eller uautoriserede ændringer kan resultere i alvorlig personskade, død, maskinskade og bortfald af garanti. Sørg altid for korrekt installation, justering og brug inden for specificerede grænser. Brug ikke beskadigede eller synligt defekte komponenter. Se din produktmanual for korrekt brug og specifikationer. Hvis du har spørgsmål om et Morehouse Instrument Company-produkts egenskaber eller begrænsninger, eller for at få adgang til en manual, bedes du kontakte din salgsrepræsentant eller sende en e-mail til info@mhforce.com.

 **Nederlands**

WAARSCHUWING: Morehouse Instrument Company producten zijn precisie-instrumenten voor specifieke kracht- of koppelkalibratietoepassingen. Onjuist gebruik, het overschrijden van de vermelde capaciteiten of ongeautoriseerde wijzigingen kunnen leiden tot ernstig letsel, overlijden, schade aan de machine en het vervallen van de garantie. Zorg altijd voor een correcte installatie, uitlijning en gebruik binnen de gespecificeerde grenzen. Gebruik geen beschadigde of zichtbaar aangetaste onderdelen. Raadpleeg uw producthandleiding voor correct gebruik en specificaties. Als u vragen heeft over de mogelijkheden of beperkingen van een Morehouse Instrument Company product, of om toegang te krijgen tot een handleiding, neem dan contact op met uw verkoopvertegenwoordiger of stuur een e-mail naar info@mhforce.com.

 **Vlaams**

WAARSCHUWING: Morehouse Instrument Company producten zijn precisie-instrumenten voor specifieke kracht- of koppelkalibratietoepassingen. Onjuist gebruik, het overschrijden van de vermelde capaciteiten of ongeautoriseerde wijzigingen kunnen leiden tot ernstig letsel, overlijden, schade aan de machine en het vervallen van de garantie. Zorg altijd voor een correcte installatie, uitlijning en gebruik binnen de gespecificeerde grenzen. Gebruik geen beschadigde of zichtbaar aangetaste onderdelen. Raadpleeg uw producthandleiding voor correct gebruik en specificaties. Als u vragen heeft over de mogelijkheden of beperkingen van een Morehouse Instrument Company product, of om toegang te krijgen tot een handleiding, neem dan contact op met uw verkoopvertegenwoordiger of stuur een e-mail naar info@mhforce.com.

 **Français**

AVERTISSEMENT: Les produits Morehouse Instrument Company sont des instruments de précision destinés à des applications spécifiques d'étalonnage de force ou de couple. Une utilisation incorrecte, un dépassement des capacités indiquées ou des modifications non autorisées peuvent entraîner des blessures graves, la mort, des dommages à la machine et l'annulation de la garantie. Veuillez toujours à une installation, un alignement et une utilisation corrects dans les limites spécifiées. N'utilisez pas de composants endommagés ou visiblement compromis. Reportez-vous au manuel de votre produit pour une utilisation correcte et les spécifications. Si vous avez des questions sur les capacités ou les limites d'un produit Morehouse Instrument Company, ou pour accéder à un manuel, veuillez contacter votre représentant commercial ou envoyer un courriel à info@mhforce.com

 **Deutsch**

WARNUNG: Produkte der Morehouse Instrument Company sind Präzisionsinstrumente für spezifische Kraft- oder Drehmomentkalibrierungsanwendungen. Unsachgemäßer Gebrauch, Überschreitung der angegebenen Kapazitäten oder unbefugte Änderungen können zu schweren Verletzungen, Tod, Maschinenschäden und zum Erlöschen der Garantie führen. Stellen Sie stets eine korrekte Installation, Ausrichtung und Verwendung innerhalb der angegebenen Grenzen sicher. Verwenden Sie keine beschädigten oder sichtbar beeinträchtigten Komponenten. Beachten Sie Ihr Produkthandbuch für die korrekte Verwendung und Spezifikationen. Wenn Sie Fragen zu den Fähigkeiten oder Einschränkungen eines Produkts der Morehouse Instrument Company haben oder um auf ein Handbuch zuzugreifen, wenden Sie sich bitte an Ihren Vertriebsmitarbeiter oder senden Sie eine E-Mail an info@mhforce.com.

 **Italiano**

AVVERTENZA: I prodotti Morehouse Instrument Company sono strumenti di precisione per applicazioni specifiche di calibrazione della forza o della coppia. L'uso improprio, il superamento delle capacità dichiarate o le modifiche non autorizzate possono provocare gravi lesioni, morte, danni alle macchine e l'annullamento della garanzia. Assicurarsi sempre di una corretta installazione, allineamento e utilizzo entro i limiti specificati. Non utilizzare componenti danneggiati o visibilmente compromessi. Fare riferimento al manuale del prodotto per l'uso corretto e le specifiche. In caso di domande sulle capacità o sui limiti di un prodotto Morehouse Instrument Company, o per accedere a un manuale, contattare il proprio rappresentante di vendita o inviare un'e-mail a info@mhforce.com.

 **Norsk**

ADVARSEL: Morehouse Instrument Company-produkter er presisjonsinstrumenter for spesifikke kraft- eller momentkalibreringsapplikasjoner. Feil bruk, overskridelse av oppgitte kapasiteter eller uautoriserte modifikasjoner kan føre til alvorlig personskade, død, maskinskade og bortfall av garanti. Sørg alltid for riktig installasjon, justering og bruk innenfor angitte grenser. Ikke bruk skadede eller synlig defekte komponenter. Se produktets bruksanvisning for riktig bruk og spesifikasjoner. Hvis du har spørsmål om et Morehouse Instrument Company-produkts egenskaper eller begrensninger, eller for å få tilgang til en manual, vennligst kontakt din salgsrepresentant eller send en e-post til info@mhforce.com.

 **Português**

AVISO: Os produtos da Morehouse Instrument Company são instrumentos de precisão para aplicações específicas de calibração de força ou torque. O uso inadequado, a superação das capacidades declaradas ou modificações não autorizadas podem resultar em ferimentos graves, morte, danos à máquina e anulação da garantia. Certifique-se sempre da instalação, alinhamento e uso corretos dentro dos limites especificados. Não use componentes danificados ou visivelmente comprometidos. Consulte o manual do seu produto para uso e especificações adequados. Se você tiver dúvidas sobre os recursos ou limitações de um produto da Morehouse Instrument Company, ou para acessar um manual, entre em contato com seu representante de vendas ou envie um e-mail para info@mhforce.com.

 **Español**

ADVERTENCIA: Los productos de Morehouse Instrument Company son instrumentos de precisión para aplicaciones específicas de calibración de fuerza o par. El uso inadecuado, la superación de las capacidades indicadas o las modificaciones no autorizadas pueden provocar lesiones graves, la muerte, daños en la máquina y la anulación de la garantía. Asegúrese siempre de que la instalación, la alineación y el uso sean correctos dentro de los límites especificados. No utilice componentes dañados o visiblemente comprometidos. Consulte el manual de su producto para conocer el uso y las especificaciones correctas. Si tiene preguntas sobre las capacidades o limitaciones de un producto de Morehouse Instrument Company, o para acceder a un manual, póngase en contacto con su representante de ventas o envíe un correo electrónico a info@mhforce.com.

 **Svenska**

WARNING: Morehouse Instrument Company's produkter är precisionsinstrument för specifika kraft- eller vridmomentkalibreringsapplikationer. Felaktig användning, överskridande av angivna kapaciteter eller obehöriga modifieringar kan leda till allvarliga personskador, dödsfall, maskinskador och upphävande av garantin. Se alltid till att installationen, inriktningen och användningen är korrekt inom angivna gränser. Använd inte skadade eller synligt komprometterade komponenter. Se din produkthandbok för korrekt användning och specifikationer. Om du har frågor om ett Morehouse Instrument Company- produkts kapacitet eller begränsningar, eller för att komma åt en manual, vänligen kontakta din säljrepresentant eller e-posta info@mhforce.com.