

Operation and Instruction Manual

Benchtop Calibrating Machine (BCM)



Table of Contents

Introduction	3
Description	3
Components	4
Construction	4
Dimensions and Weight	6
Operation Instructions	7
Installation of Force Standard	8
Compression and Tension Setup	12
Measurement and Calibration	14
Applying Calibration Forces	14
Force Control	14
Maintenance	15
Safety	16
Parts	18
Warning	20

Introduction

The Morehouse Benchtop Calibrating Machine (BCM) is a force calibration system that is capable of calibrating a large variety of force instruments in compression and tension. The machine generates calibration forces up to 10,000 lbf in both compression and tension modes while giving the operator fine control over the applied force to maintain the calibration target points accurately. The machine utilizes mechanical force application apparatus for minimum maintenance requirements, which makes it even more suitable for field and mobile applications. Although the BCM is relatively small in size, it features a fairly large calibration area which enables calibrating the largest force measuring equipment on the market up to 10,000 lbf capacity. The machine is also equipped with a set of automatic alignment features to reduce misalignment errors in force calibration.

The BCM uses highly accurate Morehouse Shear Web load cells as a reference standard to measure the applied force to the Unit Under Test (UUT). These load cells, combined with Morehouse's accurate deadweight calibration, make the BCM a highly accurate system with a Calibration and Measurement Capability (CMC) of better than 0.03 % of applied force.

Depending on the type and capacity of the instruments needed to be calibrated by the user, various standard load cell capacities can be utilized to cover different ranges. The adjustment and force control on the machine are done manually by the user and the machine does not need any source of electrical or hydraulic power to operate. However, electrical power might be needed to take output readings from standard reference load cells or units under test.

Morehouse offers a set of threaded tension adapters, which can be purchased to perform tension calibration on equipment with the most common thread sizes on several types of instruments, such as load cells and ring force gauges. In addition, Morehouse's 12K lbf Adaptable Clevis Kit is compatible with the BCM, which allows for calibrating numerous models of crane scales, dynamometers, and tension links from different manufacturers. In addition, Morehouse offers several types of custom adapters that could be used in conjunction with the BCM to calibrate any specialty force-measuring instrument.

Description

Components

A standard Benchtop Calibrating Machine includes the following main components (Figure 1):

- | | |
|--|-----------------------------------|
| 1. Base plate | 6. Fine control shaft |
| 2. Guide posts | 7. Fast adjustment shaft |
| 3. Force standard reference load cell with indicator | 8. Handwheel |
| 4. Quick-adjust stage beam | 9. Coupling nut adapter |
| 5. Mechanical screw jack | 10. Compression base block |
| | 11. Compression ball seat adapter |

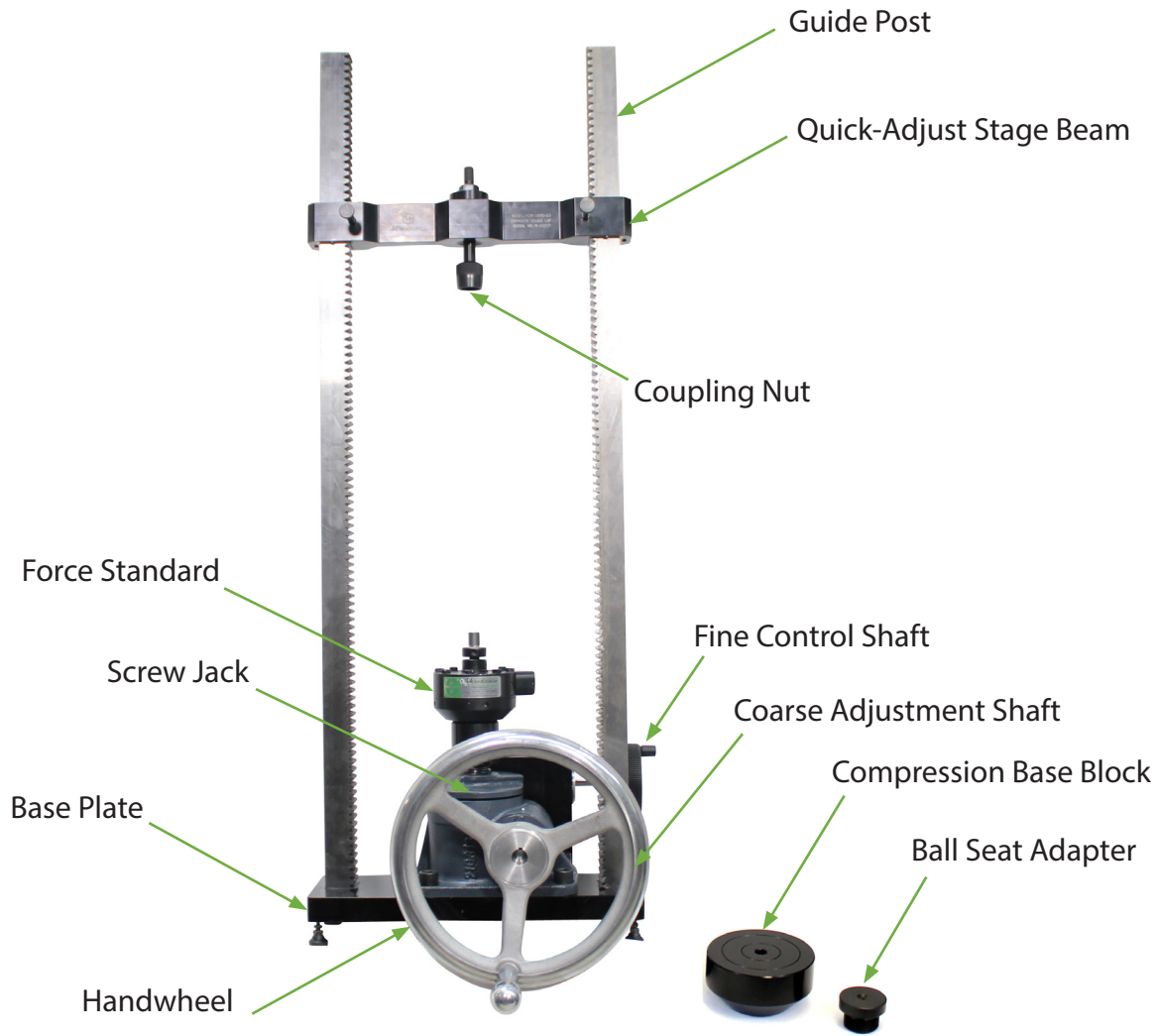

Figure 1: Standard Components of a Benchtop Calibrating Machine

Construction

The Benchtop Calibrating Machine is manufactured from high-quality material and to high-quality standards to provide users with a reliable and accurate force calibration system. Calibration force is generated by a mechanical screw jack up to 10,000 lbf in both tension and compression.

The position of the stage beam on the guideposts can be quickly adjusted to accommodate different calibration setups. The user can push the plunger buttons on two sides of the stage beam to release it and slide it up or down to reach the desired opening space. Then, the stage beam position can be locked again by releasing the plunger buttons at 0.4 in. intervals.

The machine is operated by turning either the FAST or FINE input shafts in front of the mechanical screw jack to move the jack's lead screw up or down based on the direction of turning the shaft and, consequently, generate compressive or tensile forces.

A lever on the rear of the machine is moved to switch between the coarse and fine adjustment wheels (see Fig 2). To switch between coarse and fine adjustment shafts, follow the directions on the label next to the spring plunger (see Fig 2).

A fine control shaft is used to apply forces during calibration. When this input shaft is used, the machine provides fine control over the entire range of forces. In addition, the handwheel can be turned very smoothly and with little effort by the user, even at the capacity force (10,000 lbf).

Coarse adjustment shaft used for initial adjustment of the jack screw position. Turning this shaft moves the jack up or down faster than the fine control shaft. However, it needs much higher torque, and the operator typically needs both hands to turn it.

The standard Benchtop Calibrating Machine has a Compression Base Block and a Compression Ball Seat adapter to simplify calibration of compression-only instruments. In addition, the machine features a swiveling coupling nut underneath the stage beam. This coupling nut makes changing setups easier and includes two spherical contact surfaces to align the machine's load line with the standard load cell and reduce misalignment errors..



Dimensions and Weight

A Benchtop Calibrating Machine, Model BCM-10MD-1 weighs 150 lbs. without a standard load cell. Depending on the load cell standard, accessories, and shipping box that might be used with the machine, the overall weight may vary. Figure 2 presents the overall dimensions of a Benchtop Calibrating Machine.

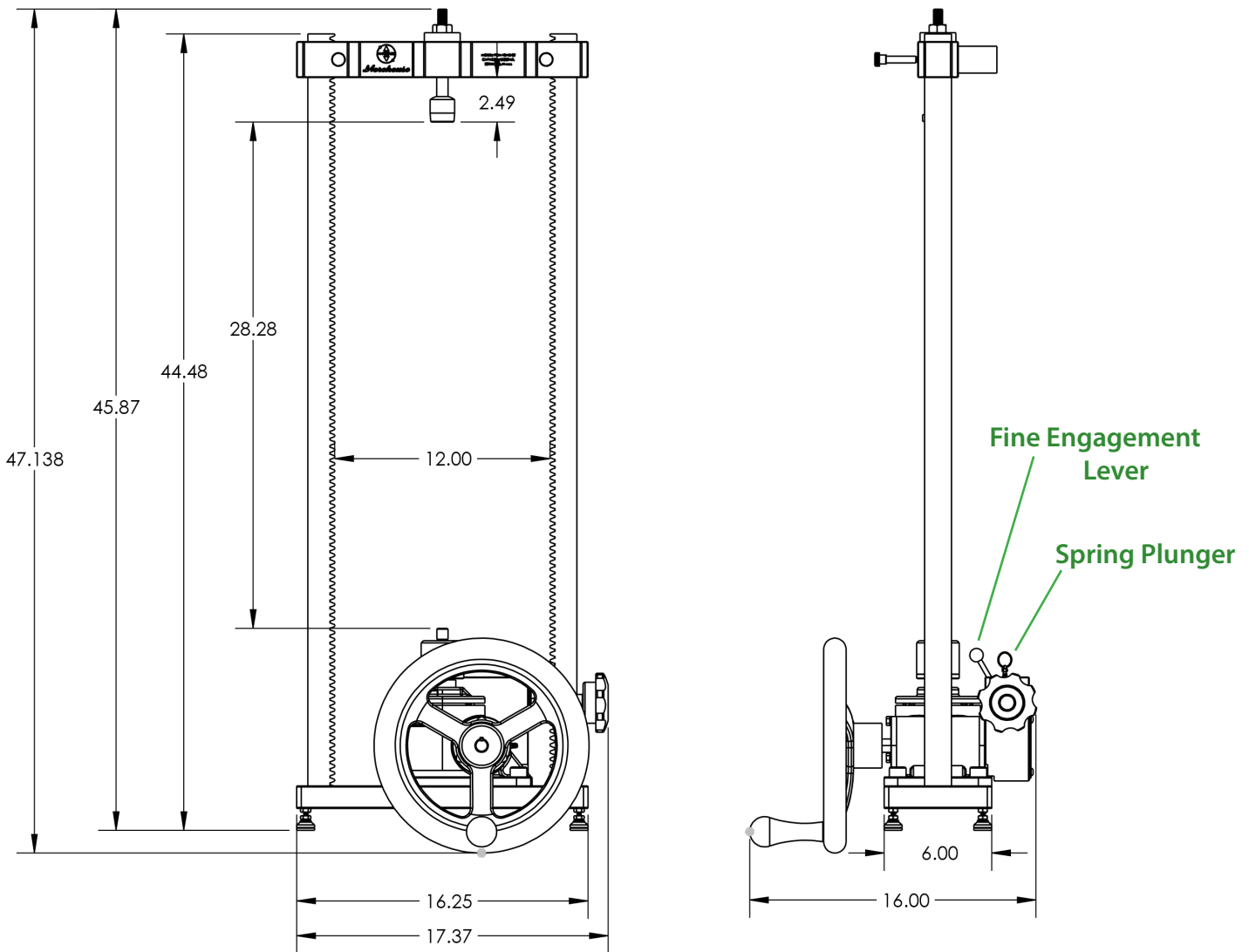

Figure 2: Dimensions of Benchtop Calibrating Machine (Model: BCM-10MD-1)

Operation Instructions

CHANGING ADJUSTMENT MODES

1. Lift the ring on the plunger and pull the plunger until the fine adjustment shaft rotates freely.
2. If adjusting from coarse adjustment to fine adjustment, push the lever away from the user. If adjusting from fine adjustment to coarse adjustment, pull the lever towards the user. Refer to the label on the control box.
3. Ensure the plunger is fully seated after changing the lever position. Do not force lever! If the fine adjustment is not engaging, rotate the fine adjustment handwheel while moving lever.

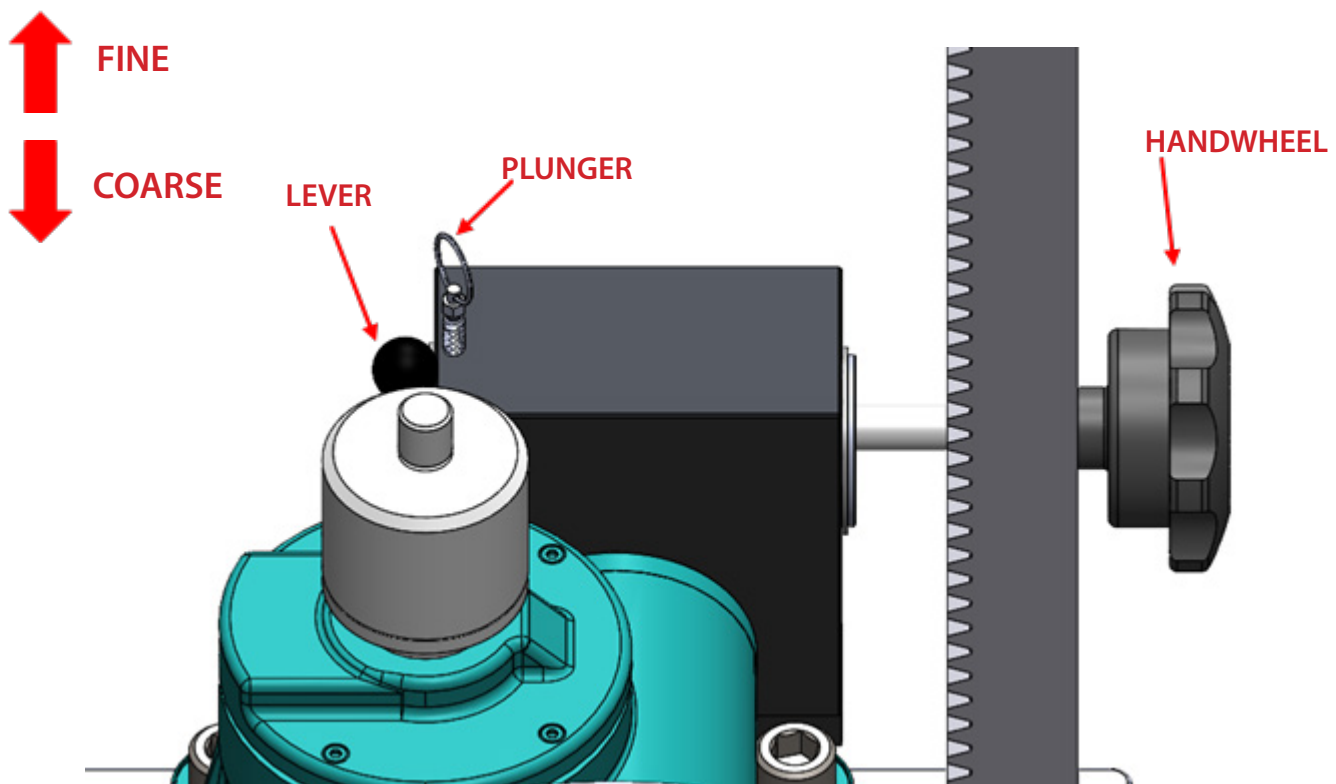

FIGURE 3: COARSE ADJUSTMENT ENGAGED



Operation Instructions

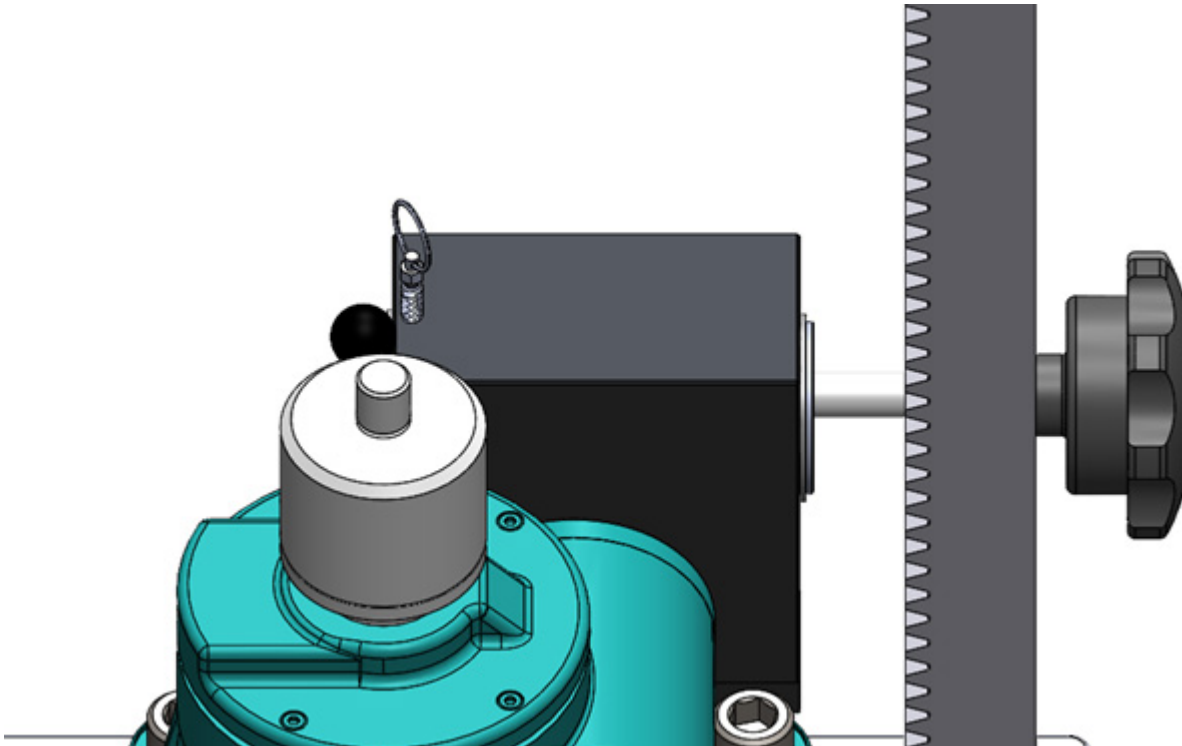

FIGURE 4: FINE ADJUSTMENT ENGAGED

Operation Instructions

Installation of Force Standard

The reference standard load cell must be properly installed into the Benchtop Calibrating Machine prior to doing any calibrations. In general, for each test point, the machine applies the same amount of force to both the reference load cell and the unit under test. The readings from the reference standard are used to adjust and control the applied force to the unit under test in the machine.

In a Benchtop Calibrating Machine, the reference standard load cell is installed on top of the screw jack. A reference standard mounting adapter is included with each machine. As depicted in Figure 3, this adapter is threaded to the top of the jack from one side. The top side of the adapter with external thread is then used to install the reference standard.

By default, the reference standard mounting adapter has an external 0.625"-18 UNF thread on the top side to accommodate a Morehouse Shear Web load cell for capacities 10,000 lbf and lower. If any other thread size is needed to mount other types of load cells, consult the Morehouse Sales team when placing an order.

When a shear web load cell is calibrated by the Morehouse Force Calibration Laboratory, the compression force is applied through the bottom shoulder of the cell, unless otherwise specified by the customer. Therefore, applying the compression load through the bottom thread will cause some additional errors from the reported calibration values.

The reference standard mounting adapter was designed to ensure that the load cell is loaded through the bottom shoulder and not threads when in compression. To achieve this goal, the user must make sure that the reference standard load cell is tightened against the mounting adapter. Normally, after installation of a reference standard load cell, it does not need to come out of the machine frequently. However, after each time it is taken out for calibration, switching standards, or maintenance, the proper installation must be ensured before starting a calibration

IMPORTANT TIP: A standard load cell must be snugly tightened against the mounting adapter before compression calibration. The goal is to have the bottom shoulder of the reference standard in contact with the mounting adapter.

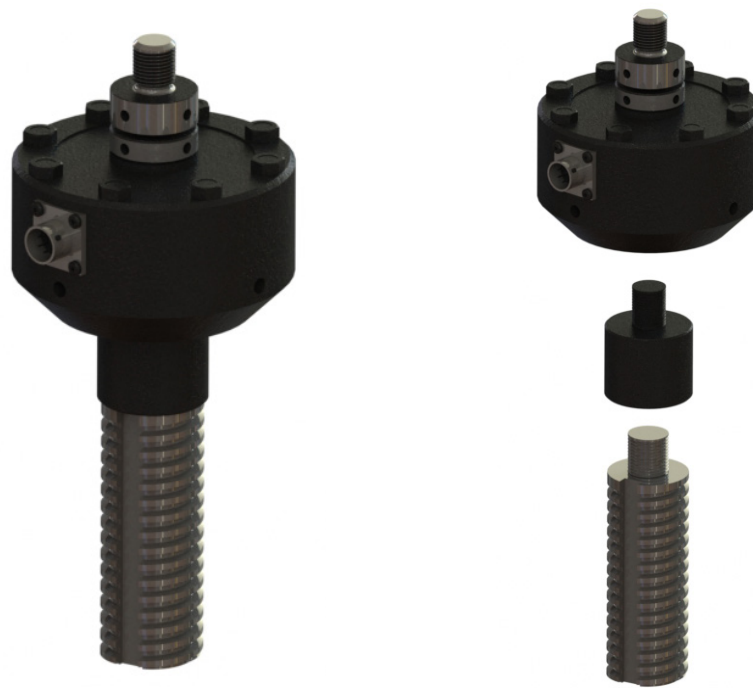

Figure 5: Installation of Reference Load Cell Using the Standard Mounting Adapter

Compression and Tension Setup

A compression bearing block and a ball seat adapter are included with every Benchtop Calibrating Machine. These adapters can be used to calibrate almost any compression-only force instrument up to 10,000 lbf capacity. By default, the compression bearing block is manufactured by an internal 0.625"-18 UNF thread for installation on Morehouse Shear Web standard load cells. If other types of load cells need to be used as standard reference, the Morehouse Sales team must be consulted when ordering a machine. To set up the calibration apparatus for a compression-only calibration:

1. Install the compression base block on top of the reference standard load cell. Ensure that the internal threads underneath the bearing block are fully engaged with the threaded stud on the load cell.
2. Install the ball seat adapter to the coupling nut underneath the stage beam of the Benchtop Calibrating Machine.
3. Place the unit under test on the compression base block. The hole at the center of the base block can be used with alignment plugs to align the unit under test with the load line accurately. In addition, Morehouse offers various ball adapters to be mounted on top of the unit under test for better stress distribution within the instrument and more accurate calibration results.
4. Release the two latches on the stage beam by pushing the plunger nubs on both sides. Then, move the stage beam up or down while holding the plungers in to have the top of the unit under test close to the ball seat adapter. Release the plungers to have the stage beam position locked.

5. Use the lever on the rear of the machine to engage the coarse adjustment shaft and move the jack up to position the unit under test as close as possible to the ball seat adapter and coupling nut. Use the combination of adjustments provided by the stage beam and screw jack to complete the setup with minimal effort from the operator. Pull the plungers to check and ensure that they are fully engaged. A groove line is cut on the plunger handles which must be visible when the plungers are fully engaged, and handles are completely pulled out. Figure 4b illustrates a completed compression calibration setup with an S-Beam load cell as the UUT.

To set up a tension calibration, special adapters will be needed based on the type and configuration of the unit under test. Morehouse manufactures several adapter kits designed for tension calibration in Benchtop Calibrating Machines. Prior to assembling a tension calibration setup, the proper adapters with appropriate safety precautions must be acquired. To set up a tension calibration:

1. Check the mechanical jack to see that it is not retracted all the way down and has at least about 0.5" of travel left in the downward direction. Adjust the height of screw jack if needed using the front hand wheel.
2. The tension unit under test is coupled to the top of the standard reference load cell using adapters. If the unit under test has an internal threaded hole with 0.625"-18 thread size, it can be directly installed on the threaded stud supplied with Morehouse Shear Web standard load cells.
3. Another adapter will be needed to connect the unit under test to the swiveling coupling nut of the Benchtop calibrating machine. This adapter is mounted to the unit under test from one side and from other side is threaded into the coupling nut which has a 1.125"-12 UNF-2B thread. Install this adapter on the unit under test and make sure full engagement is made if the adapter is a threaded type.
4. Release the two latches on the stage beam by pushing the plunger nubs on both sides. Then, move the stage beam up or down while holding the plungers in to have the top of the unit under test and its attached adapter in contact with the swiveling coupling nut underneath the stage beam. Release the plungers to have the stage beam position locked.
5. Use the lever on the rear of the machine to engage the coarse adjustment shaft. Use the combination of the adjustments provided by the stage beam and the screw jack to the turn the coupling nut onto the adapter on top of the unit under test until full thread engagement is achieved. Pull the plungers to check and ensure that they are fully engaged. A groove line is cut on the plunger handles which must be visible when the plungers are fully engaged, and handles are completely pulled out. Figure 4a illustrates a completed tension calibration setup with a shear web load cell as the UUT.
6. Some instruments may have special calibration requirements. Check the specifications and calibration instructions of the unit under test before calibration setup to ensure that the right type of adapters and setup is available for calibration.

Note: Before applying any tension forces, check the position of the standard mounting adapter and ensure that there is enough space for it to move downward before making contact with the jack body. Pulling the standard mounting adapter down against the jack body may generate large forces and cause permanent damage to the jack.

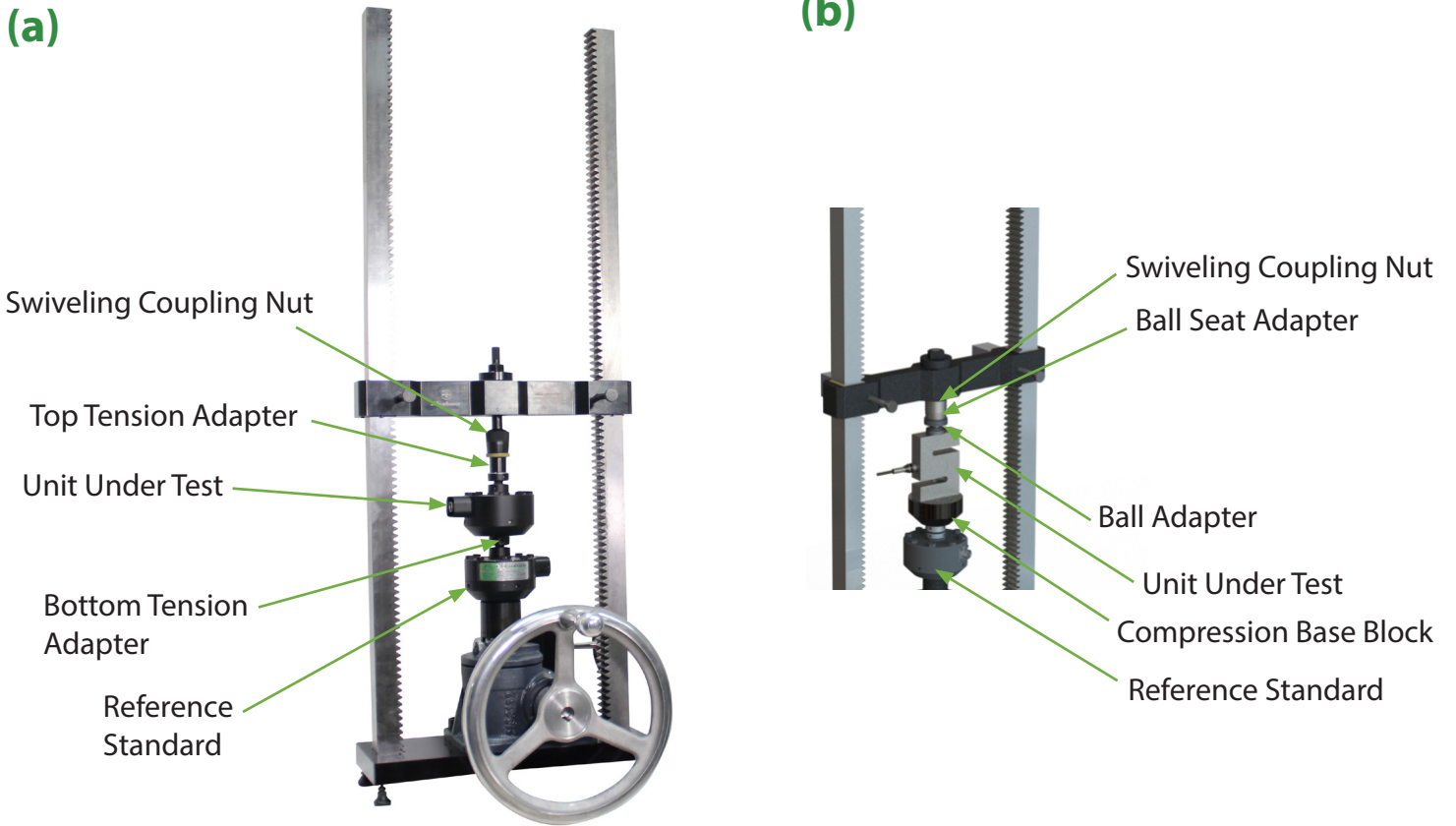

Figure 6: Calibration Setup: a) Tension b) Compression



Morehouse offers various types of adapters to make tension calibration setups. For calibrating crane scales, dynamometers, and tension links, Morehouse has developed the [12K lbf Adaptable Clevis Kit](#). This kit includes a set of clevises and various pin sizes to calibrate several types of instruments using the pin sizes recommended by their manufacturers. Figure 5 demonstrates a tension calibration setup for a 10,000 lbf crane scale using the 12K lbf Adaptable Clevis Kit.

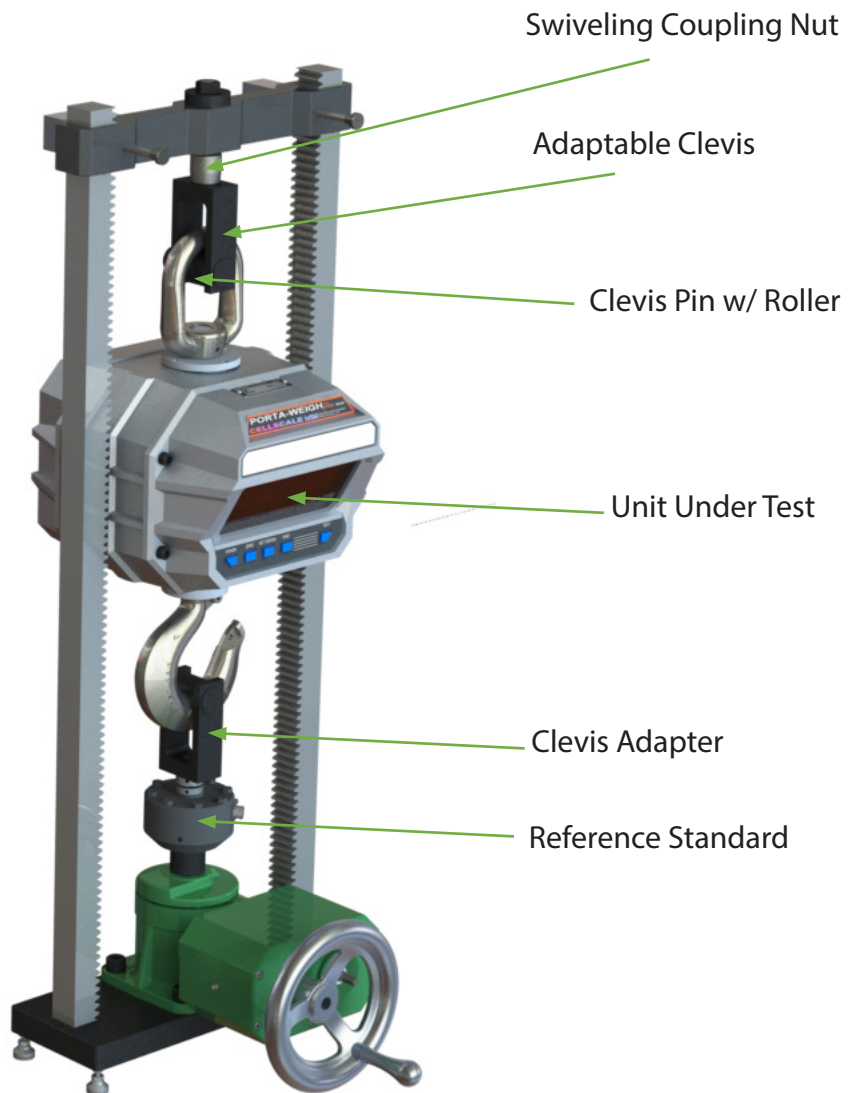

Figure 7: Crane Scale Calibration Setup Using Morehouse 12K lbf Adaptable Clevis Kit

Note: The machine pictured is an old design and is shown for reference only

Measurement and Calibration

Applying Calibration Forces

After the initial setup, the system is ready for starting the calibration test. Compression or tension force is applied by turning the handwheel clockwise or counterclockwise, based upon using the fine or coarse control shafts. Normally, compression force is applied when the jack screw moves up, and contrarily, tension force is generated when the jack screw moves down. For calibrating digital instruments such as load cells, normally after exercising the instrument, a small contact force is applied and the indicators for both standard and unit under test are tared to zero.

To apply a predetermined certain amount of force, start turning the handwheel in the appropriate direction while watching the output of the reference load cell. Morehouse offers various types of load cell indicators which can be used to monitor the reference load cell output in ratio metric mV/V, or direct force values in engineering units based on the user's preferences. Once a certain amount of force is reached, if the user stops the movement of the jack, the creep in the force instrument and the machine might cause some changes in the force value. However, the user can continuously adjust the position of the mechanical jack to keep the force in the vicinity of the target force.

The force applied to the calibration setup is generated by the movement of the mechanical screw jack. In other words, the jack converts the torque applied to the handwheel by the user into unidirectional force. Therefore, the force applied by the jack is dependent on the amount of torque applied by the user, and higher amount of torque is required to generate higher forces. As the applied force increases, the handwheel feels tighter to turn. This is normal as long as the applied force stays within the rated capacity of the machine and instruments under calibration.

Force Control

The Benchtop Calibrating Machine offers an exceptional capability in controlling the calibration force when compared to the other calibration systems commercially available on the market. The machine provides a two-speed loading jack: coarse adjustment for completing the initial setup, and fine adjustment for application of the target forces. The fine control mechanism enables controlling the force very accurately. Although, capability of controlling the force can change to some extent based on the experience of the user, quality of the force reference standards, and indicator system. Preliminary tests have shown that a user can control the calibration force in Benchtop Calibrating Machine within ± 0.001 % of the reference standard capacity, when a Morehouse Ultra-Precision Shear Web load cell is used as the standard reference with a high accuracy indicator. For example, if a 10,000 lbf Ultra-Precision load cell is used, an experienced user can control the test forces within ± 0.1 lbf using the fine control shaft on the screw jack.

Maintenance

The mechanical jacks in a Benchtop Calibrating Machine are lubricated before leaving the manufacturing plant. For normal operation, jacks should be greased about once per year. Grease through fitting on the jack with hand operated equipment. Do not allow the jack to operate unlubricated. It is the responsibility of the user to maintain sufficient lubrication of the jack and to the lifting screw.

The products listed below are recommended by the lubricant manufacturers to meet the requirements for normal operation. The listing of brand names is solely for the convenience of users of equipment and their lubricant suppliers; it does not constitute any endorsement. Morehouse assumes no responsibilities for quality, performance, or availability of any listed products.

Table 1: Recommended Lubricants for the Screw Jack

Company	Brand Name
Mobilgrease	XHP 461
Mobilgrease	XHP 221
Shell Oil Company	Retinax HD NLGI 1
Shell Oil Company	Albina SLC 460
Mobil Oil	Mobilith SHC PM 460

The stage beam of the machine is in contact with the guideposts through a set of bronze bushings to avoid jamming in the stage beam slide. To keep the slide of the stage beam smooth, the surface area of the guideposts need to stay clean and free of debris. In addition, once the movement of the stage beam is not smooth enough, applying some oil to the bushings and guideposts' flat surfaces will smoothen the slide again. Upon completion of routine inspection and preventative maintenance procedures, coat all unpainted guidepost surfaces with some light machine oil to prevent rusting on these surfaces.

Safety

For general guidelines about force calibration safety, refer to the Morehouse [Force Measurement Equipment Safety](#) guide. In addition, the following safety practices must be exercised when using a Benchtop Calibrating Machine. To avoid situations that may cause personal injuries, wear eye protection at all times when using a Benchtop Calibrating Machine or any other force calibration machine.

- Any adapter or accessory you may design, make, or purchase for use with a Benchtop Calibrating Machine, or force measuring instrument, must be of proper design and made from steel of the proper strength to withstand the forces to which it is subjected. It is important that adapters and accessories be test loaded under safe conditions prior to actual use with an instrument. Equipment should not be used beyond its maximum rated capacity. Failure to use the proper strength material may result in serious injury or death.
- Inspect all parts of the machine regularly to ensure all the components are free of any defects and are assembled properly. Look for any damaged connections or loose bolts. Contact Morehouse with any questions about the assembly of the parts, or for ordering new parts.
- The quick-adjust latches on the stage beam have a critical role in load bearing capability of the Benchtop Calibrating Machine. Before starting to apply a force, check the latches to ensure that they are completely pulled out, and the holding latches are fully engaged. Figure 6 demonstrates how the engagement of the stage beam latches need to be checked.
- The spherical nut on top of the tension rod assembly is also critical in load bearing capability of the machine. Before starting a tension calibration, check the spherical nut on top of the stage beam and ensure that the nut is fully engaged with the tension rod on the threads. The nut must not be tightened against the alignment busing and the tension rod should be able to move freely.
- When the machine is applying force, do not touch the moving parts of the machine such as jack screw, quick-change latches, guideposts, stage beam, etc.
- Always operate the machine on a flat and level surface with no risk of falling down or losing sight of it. When the machine is under load, prevent any impact or sudden movements to the machine.
- The Benchtop Calibrating Machine can only be used to generate forces within the rated capacity of the machine. Trying to generate higher forces may cause damage to the machine and result in a dangerous situation for the user. All necessary safety precautions for using manual machinery must be carefully exercised when using the Benchtop Calibrating Machine.
- Read the instruction manual carefully and ensure that anyone who intends to operate the machine has proper training on safe practices of using Benchtop Calibrating Machine.
- Applying forces to equipment and instruments is inherently dangerous. This document does not, and cannot, foresee all safety considerations in your testing and application environments. It is important to give careful consideration to any application of force.
- The machine is supplied with four bench securing mounts (item 21 in Fig 7). These slide over the leveling feet. Customers must have an engineer review, specify and select the bolts / lag screws to secure the machine. Morehouse cannot provide recommendations due to the variety of customer tables.

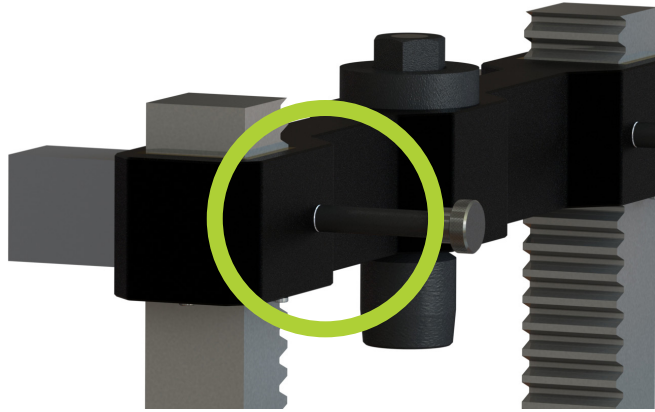
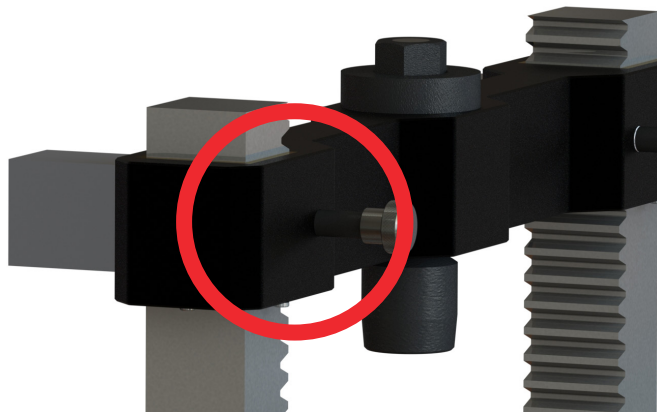

Figure 8: Quick-Change Latch: a) Correct: Fully Engaged



b) Incorrect: Partially Engaged



Parts

To order parts and accessories for your Benchtop Calibrating Machine, contact the Morehouse Sales team. Figure 7 and Table 2 demonstrate the parts included in a Benchtop Calibrating Machine Model BCM-10MD-1.

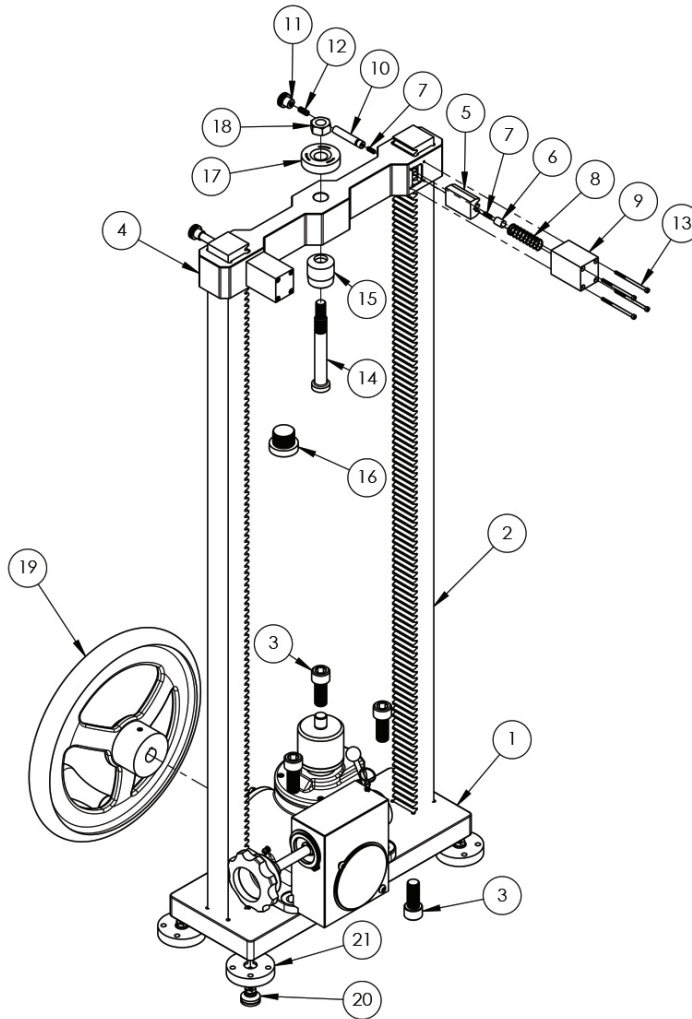



Figure 9: General Assembly of a Benchtop Calibrating Machine, Model: BCM-10MD-1



Table 2: Parts List for Benchtop Calibrating Machine, Model: BCM-10MD-1

NO.	PART NUMBER	DESCRIPTION	QTY.
1	PC-10-013-01	BASE PLATE	1
2	PC-10-014-01	GEAR RACK	2
3	ZF-36-3354-ALLOY	SOCKET HEAD CAP SCREW	6
4	PC-10-016-01	STAGE BEAM	1
5	PC-10-011-01	GEAR PLUNGER	2
6	PC-10-015-01	SPRING GUIDE	2
7	ZF-09-018	SET SCREW	4
8	ZM-17-005	COMPRESSION SPRING	2
9	PC-10-026-01	PLUNGER COVER	2
10	PC-10-027-01	PLUNGER ROD	2
11	ZF-22-001	STEEL ROUND KNOB	2
12	91375A539	SET SCREW	2
13	ZF-01-058	SOCKET HEAD CAP SCREW	8
14	TR-12-3.5	TENSION ROD	1
15	PC-10-010-01	COUPLING NUT	1
16	PC-2-062-01	COMP BALL SEAT ADAPTER	1
17	TB-12-0.750	SPHERICAL ALIGNMENT BUSHING	1
18	TH-12	SPHERICAL NUT	1
19	3724T64	HAND WHEEL	1
20	ZM-31-001	LEVELING FOOT	4
21	BM-0001	BENCH MOUNT	4

 **WARNING:** Morehouse Instrument Company products are precision instruments for specific force or torque calibration applications. Improper use, exceeding stated capacities, or unauthorized modifications can result in severe injury, death, machine damage, and warranty voiding. Always ensure proper installation, alignment, and use within specified limits. Do not use damaged or visibly compromised components. Refer to your product manual for proper use and specifications. If you have questions about a Morehouse Instrument Company product's capabilities or limitations or to access a manual, please contact your sales representative or email info@mhforce.com.

 Dansk

ADVARSEL: Morehouse Instrument Company produkter er præcisionsinstrumenter til specifikke kraft- eller momentkalibreringsapplikationer. Forkert brug, overskridelse af angivne kapaciteter eller uautoriserede ændringer kan resultere i alvorlig personskade, død, maskinskade og bortfald af garanti. Sørg altid for korrekt installation, justering og brug inden for specificerede grænser. Brug ikke beskadigede eller synligt defekte komponenter. Se din produktmanual for korrekt brug og specifikationer. Hvis du har spørgsmål om et Morehouse Instrument Company-produkts egenskaber eller begrænsninger, eller for at få adgang til en manual, bedes du kontakte din salgsrepræsentant eller sende en e-mail til info@mhforce.com.

 Nederlands

WAARSCHUWING: Morehouse Instrument Company producten zijn precisie-instrumenten voor specifieke kracht- of koppelkalibratietoepassingen. Onjuist gebruik, het overschrijden van de vermelde capaciteiten of ongeautoriseerde wijzigingen kunnen leiden tot ernstig letsel, overlijden, schade aan de machine en het vervallen van de garantie. Zorg altijd voor een correcte installatie, uitlijning en gebruik binnen de gespecificeerde grenzen. Gebruik geen beschadigde of zichtbaar aangetaste onderdelen. Raadpleeg uw producthandleiding voor correct gebruik en specificaties. Als u vragen heeft over de mogelijkheden of beperkingen van een Morehouse Instrument Company product, of om toegang te krijgen tot een handleiding, neem dan contact op met uw verkoopvertegenwoordiger of stuur een e-mail naar info@mhforce.com.

 Vlaams

WAARSCHUWING: Morehouse Instrument Company producten zijn precisie-instrumenten voor specifieke kracht- of koppelkalibratietoepassingen. Onjuist gebruik, het overschrijden van de vermelde capaciteiten of ongeautoriseerde wijzigingen kunnen leiden tot ernstig letsel, overlijden, schade aan de machine en het vervallen van de garantie. Zorg altijd voor een correcte installatie, uitlijning en gebruik binnen de gespecificeerde grenzen. Gebruik geen beschadigde of zichtbaar aangetaste onderdelen. Raadpleeg uw producthandleiding voor correct gebruik en specificaties. Als u vragen heeft over de mogelijkheden of beperkingen van een Morehouse Instrument Company product, of om toegang te krijgen tot een handleiding, neem dan contact op met uw verkoopvertegenwoordiger of stuur een e-mail naar info@mhforce.com.

 Français

AVERTISSEMENT: Les produits Morehouse Instrument Company sont des instruments de précision destinés à des applications spécifiques d'étalonnage de force ou de couple. Une utilisation incorrecte, un dépassement des capacités indiquées ou des modifications non autorisées peuvent entraîner des blessures graves, la mort, des dommages à la machine et l'annulation de la garantie. Veuillez toujours à une installation, un alignement et une utilisation corrects dans les limites spécifiées. N'utilisez pas de composants endommagés ou visiblement compromis. Reportez-vous au manuel de votre produit pour une utilisation correcte et les spécifications. Si vous avez des questions sur les capacités ou les limites d'un produit Morehouse Instrument Company, ou pour accéder à un manuel, veuillez contacter votre représentant commercial ou envoyer un courriel à info@mhforce.com

 Deutsch

WARNUNG: Produkte der Morehouse Instrument Company sind Präzisionsinstrumente für spezifische Kraft- oder Drehmomentkalibrierungsanwendungen. Unsachgemäßer Gebrauch, Überschreitung der angegebenen Kapazitäten oder unbefugte Änderungen können zu schweren Verletzungen, Tod, Maschinenschäden und zum Erlöschen der Garantie führen. Stellen Sie stets eine korrekte Installation, Ausrichtung und Verwendung innerhalb der angegebenen Grenzen sicher. Verwenden Sie keine beschädigten oder sichtbar beeinträchtigten Komponenten. Beachten Sie Ihr Produkthandbuch für die korrekte Verwendung und Spezifikationen. Wenn Sie Fragen zu den Fähigkeiten oder Einschränkungen eines Produkts der Morehouse Instrument Company haben oder um auf ein Handbuch zuzugreifen, wenden Sie sich bitte an Ihren Vertriebsmitarbeiter oder senden Sie eine E-Mail an info@mhforce.com.

 Italiano

AVVERTENZA: I prodotti Morehouse Instrument Company sono strumenti di precisione per applicazioni specifiche di calibrazione della forza o della coppia. L'uso improprio, il superamento delle capacità dichiarate o le modifiche non autorizzate possono provocare gravi lesioni, morte, danni alle macchine e l'annullamento della garanzia. Assicurarsi sempre di una corretta installazione, allineamento e utilizzo entro i limiti specificati. Non utilizzare componenti danneggiati o visibilmente compromessi. Fare riferimento al manuale del prodotto per l'uso corretto e le specifiche. In caso di domande sulle capacità o sui limiti di un prodotto Morehouse Instrument Company, o per accedere a un manuale, contattare il proprio rappresentante di vendita o inviare un'e-mail a info@mhforce.com.

 Norsk

ADVARSEL: Morehouse Instrument Company-produkter er presisjonsinstrumenter for spesifikke kraft- eller momentkalibreringsapplikasjoner. Feil bruk, overskridelse av oppgitte kapasiteter eller uautoriserte modifikasjoner kan føre til alvorlig personskade, død, maskinskade og bortfall av garanti. Sørg alltid for riktig installasjon, justering og bruk innenfor angitte grenser. Ikke bruk skadede eller synlig defekte komponenter. Se produktets bruksanvisning for riktig bruk og spesifikasjoner. Hvis du har spørsmål om et Morehouse Instrument Company-produkts egenskaper eller begrensninger, eller for å få tilgang til en manual, vennligst kontakt din salgsrepresentant eller send en e-post til info@mhforce.com.

 Português

AVISO: Os produtos da Morehouse Instrument Company são instrumentos de precisão para aplicações específicas de calibração de força ou torque. O uso inadequado, a superação das capacidades declaradas ou modificações não autorizadas podem resultar em ferimentos graves, morte, danos à máquina e anulação da garantia. Certifique-se sempre da instalação, alinhamento e uso corretos dentro dos limites especificados. Não use componentes danificados ou visivelmente comprometidos. Consulte o manual do seu produto para uso e especificações adequados. Se você tiver dúvidas sobre os recursos ou limitações de um produto da Morehouse Instrument Company, ou para acessar um manual, entre em contato com seu representante de vendas ou envie um e-mail para info@mhforce.com.

 Español

ADVERTENCIA: Los productos de Morehouse Instrument Company son instrumentos de precisión para aplicaciones específicas de calibración de fuerza o par. El uso inadecuado, la superación de las capacidades indicadas o las modificaciones no autorizadas pueden provocar lesiones graves, la muerte, daños en la máquina y la anulación de la garantía. Asegúrese siempre de que la instalación, la alineación y el uso sean correctos dentro de los límites especificados. No utilice componentes dañados o visiblemente comprometidos. Consulte el manual de su producto para conocer el uso y las especificaciones correctas. Si tiene preguntas sobre las capacidades o limitaciones de un producto de Morehouse Instrument Company, o para acceder a un manual, póngase en contacto con su representante de ventas o envíe un correo electrónico a info@mhforce.com.

 Svenska

VARNING: Morehouse Instrument Companys produkter är precisionsinstrument för specifika kraft- eller vridmomentkalibreringsapplikationer. Felaktig användning, överskridande av angivna kapaciteter eller obehöriga modifieringar kan leda till allvarliga personskador, dödsfall, maskinskador och upphävande av garantin. Se alltid till att installationen, inriktningen och användningen är korrekt inom angivna gränser. Använd inte skadade eller synligt komprometterade komponenter. Se din produkthandbok för korrekt användning och specifikationer. Om du har frågor om ett Morehouse Instrument Company- produkts kapacitet eller begränsningar, eller för att komma åt en manual, vänligen kontakta din säljrepresentant eller e-posta info@mhforce.com.