

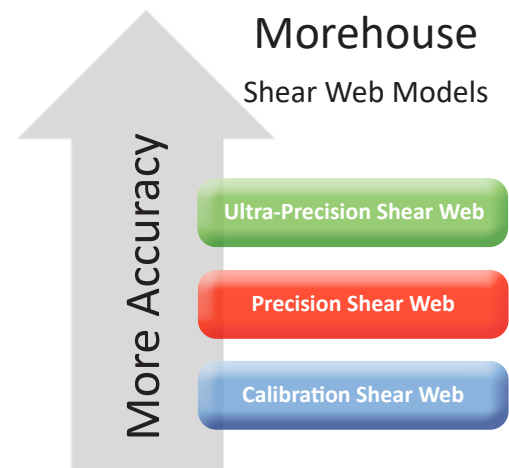

Standard Features

- » ASTM E74 performance. Lower Limit Factor (LLF) better than 0.01 %, Class A better than 4 % of capacity when used only in a single direction.¹
- » ISO 376 Class 0.5 or better (Case C only, Case D varies by capacity)
- » Compression and/or tension modes
- » Capacities from 300–200,000 lbf, or equivalent kgf/Newton
- » Direct reading calibration accuracy typically around 0.05 % of capacity
- » Available accessories such as: Quick-Change Tension Members, custom-cut protective cases, various indicators

1. When the directions are combined, there may be a reduction in the loading range. The reduction varies by capacity, and the verified range of forces could increase to 20 % of capacity.





Technical Specifications

Specifications	Model - Capacity (lbf / kN)					
	300-2K / 1-10	5K-10K / 25-50	25K-50K / 100-250	60K / 300	100K / 500	200K / 900
Accuracy						
Static Error Band, % R.O.	± 0.02	± 0.03	± 0.035	± 0.035	± 0.04	± 0.06
Non-Linearity, % R.O.	± 0.03	± 0.035	± 0.035	± 0.035	± 0.04	± 0.06
Hysteresis, % R.O.	± 0.02	± 0.04	± 0.045	± 0.045	± 0.04	± 0.06
Non-Repeatability, % R.O.	± 0.01	± 0.01	± 0.01	± 0.01	± 0.01	± 0.01
Creep, % Rdg / 20 Min.	± 0.025	± 0.025	± 0.025	± 0.025	± 0.025	± 0.025
Off-Center Load Sensitivity, %/in	± 0.10	± 0.10	± 0.10	± 0.10	± 0.10	± 0.10
Side Load Sensitivity, %	± 0.10	± 0.10	± 0.10	± 0.10	± 0.10	± 0.10
Zero Balance, % R.O.	± 1.0	± 1.0	± 1.0	± 1.0	± 1.0	± 1.0
Temperature						
Range, Compensated, °F	+15 to +115	+15 to +115	+15 to +115	+15 to +115	+15 to +115	+15 to +115
Range, Operating, °F	-65 to +200	-65 to +200	-65 to +200	-65 to +200	-65 to +200	-65 to +200
Sensitivity Effect, % Rdg / 100°F	0.08	0.08	0.08	0.08	0.08	0.08
Zero Effect, % R.O. / 100°F	0.08	0.08	0.08	0.08	0.08	0.15
Electrical						
Recommended Excitation, VDC	10	10	10	10	10	10
Input Resistance, Ω	350 +40/-3.5	350 +40/-3.5	350 +40/-3.5	350 +40/-3.5	350 +40/-3.5	350 +40/-3.5
Output Resistance, Ω	350 ± 3.5	350 ± 3.5	350 ± 3.5	350 ± 3.5	350 ± 3.5	350 ± 3.5
Sensitivity (R.O.), mV/V, Nominal	2	4	4	4	4	4
Insulation Bridge/Case, MegΩ	5000 @ 50 VDC	5000 @ 50 VDC	5000 @ 50 VDC	5000 @ 50 VDC	5000 @ 50 VDC	5000 @ 50 VDC
Mechanical						
Safe Overload, % R.O.	150	150	150	150	150	150
Weight, lbs	3.8	8.0	23.5	26.0	58.0	171.0
Flexure Material	Aluminum	Steel	Steel	Steel	Steel	Steel

Capacity (lbf)	300	500	1,000	2,000	5,000	10,000	25,000	50,000	60,000	100,000	200,000
Capacity (kN)	1	2.5	5	10	25	50	100	250	300	500	900
Part No.	PC-300	PC-500	PC-1K	PC-2K	PC-5K	PC-10K	PC-25K	PC-50K	PC-60K	PC-100K	PC-200K

Load cells for other capacities are available. Contact Morehouse for more information.



Dimensions

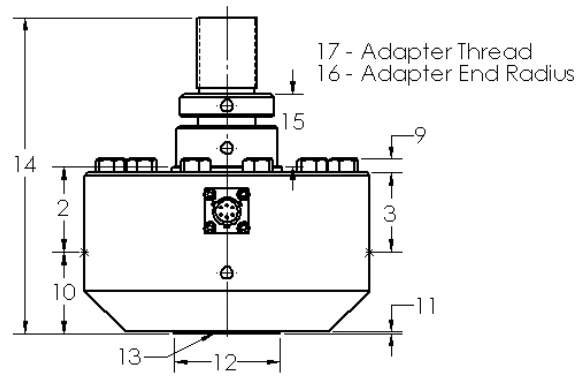
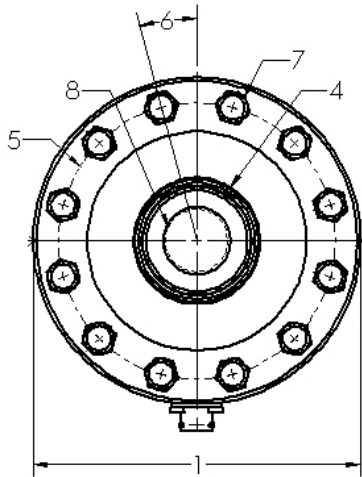

Dimensions	Model - Capacity (lbf / kN)					
	300-2K / 1-10	5K-10K / 20-50	25K-50K / 100-250	60K / 300	100K / 500	200K / 900
1 – Cell & Base Diameter (in/mm)	4.12 / 104.65	4.12 / 104.65	6.06 / 153.92	6.06 / 153.92	8.00 / 203.20	11.00 / 279.0
2 – Cell Height to Hub (in/mm)	1.38 / 35.05	1.38 / 35.05	1.75 / 44.45	2.28 / 57.91	2.50 / 63.50	3.50 / 88.90
3 – Cell Body Height (in/mm)	1.25 / 31.75	1.25 / 31.75	1.63 / 41.40	2.02 / 51.30	2.25 / 57.15	3.00 / 76.20
4 – Hub Diameter (in/mm)	1.29 / 32.77	1.29 / 32.77	2.34-2.58 / 59.44-65.53	2.65 / 67.31	3.76 / 95.50	4.81 / 122.17
5 – Mounting B.C. Diameter (in/mm)	3.50 / 88.90	3.50 / 88.90	5.13 / 130.30	5.13 / 130.30	6.50 / 165.10	9.00 / 228.60
6 – Symmetric B.C. Offset	22.5 Degrees	22.5 Degrees	15 Degrees	15 Degrees	11.25 Degrees	11.25 Degrees
7 – Mounting Hole Diameter (in/mm)	0.28 / 7.11	0.28 / 7.11	0.41 / 10.41	0.41 / 10.41	0.53 / 13.46	0.78 / 19.81
8 – Hub Thread Size, Depth (in-TPI)	0.625"-18, UNF-3B	0.625"-18, UNF-3B	1.25"-12, UNF-3B	1.50"-12, UNF-3B	1.75"-12, UNF-3B	2.75"-8, UNF-3B
9 – Bolt Head Protrusion (in/mm)	0.20 / 5.08	0.20 / 5.08	0.30 / 7.62	0.30 / 7.62	0.40 / 10.16	0.60 / 15.24
10 – Base Thickness, Total (in/mm)	1.13 / 28.70	1.13 / 28.70	1.75 / 44.45	2.00 / 50.80	2.00 / 50.80	3.00 / 76.20
11 – Base Step Height (in/mm)	0.03 / 0.76	0.03 / 0.76	0.03 / 0.76	0.03 / 0.76	0.03 / 0.76	0.03 / 0.76
12 – Base Step Diameter (in/mm)	1.25 / 31.75	1.25 / 31.75	2.25 / 57.15	2.75 / 69.85	3.00 / 76.20	4.50 / 114.3
13 – Base Thread Size, Depth (in-TPI)	0.625"-18, UNF-3B	0.625"-18, UNF-3B	1.25"-12, UNF-3B	1.50"-12, UNF-3B	1.75"-12, UNF-3B	2.75"-8, UNF-3B
14 – Total Height (in/mm)	4.38 / 111.3	4.38 / 111.3	6.50 / 162.1	7.38 / 187.45	8.75 / 218.9	10.50 / 266.7
15 – Adapter Thread Length (in/mm)	0.75 / 19.05	0.75 / 19.05	1.50 / 38.10	1.65 / 41.91	1.75 / 44.45	2.75 / 69.85
16 – Adapter End Radius (in/mm)	6.00 / 152.40	6.00 / 152.40	6.00 / 152.40	6.00 / 152.40	12.00 / 304.80	18.00 / 457.0
17 – Adapter Thread Size (in-TPI)	0.625"-18	0.625"-18	1.25"-12	1.50"-12	1.75"-12	2.75"-8



Wiring

Precision Shear Web	
Connector Pin	Description
Pin A	Excitation +
Pin B	Signal +
Pin C	Signal -
Pin D	Excitation -

