

## Dial Indicator Type Proving Ring

The Morehouse Ring Dynamometer is an instrument designed to measure mechanical forces. Its applications include the checking of mechanical and hydraulic presses, universal testing machines, Brinell hardness testers, and other force measurement systems.

The ring dynamometer consists primarily of an elastic steel ring and a precision dial indicator. When force is applied to the ring, a change in diameter, or deflection, occurs. This deflection is measured by the indicator in terms of divisions, which is translated into force by means of a calibration.



## Construction

The ring used in Morehouse Ring Dynamometer is machined from closely-controlled alloy steel which has been forged to obtain the proper metal grain structure. After rough machining, the ring is heat-treated and then ground to size.

The diametrically opposite protrusions on the outside diameter of the ring are known as external bosses, and serve as the loading surfaces of the ring. Smaller protrusions on the inside diameter of the ring are known as internal bosses and are necessary for the positive location of the deflection measuring dial indicator. Both the external and internal bosses are machined as integral parts of the ring so that the uninterrupted metal will conduct elastic reactions free from mechanical interference. The upper boss has a spherical surface while the lower external boss is ground flat. These design features facilitate axial loading which is important in accurate force measurements.

## Accuracy and Performance

Experience has proven that a ring of selected alloy steel, properly constructed and heat-treated, will perform as a nearly perfect elastic member. The limitations in accuracy are attributable to the deflection measuring devices used within this type of instrument. To further insure the desired high degree of accuracy and reliability, a special, fully jeweled indicator is used to measure ring deflection under load. Accuracies of 0.05% of load can be expected using a Morehouse Ring Dynamometer.



## Operation

The ring dynamometer is a relatively easy to operate but care should be exercised in the preliminary preparations of the calibration procedure. Before the ring dynamometer is used, it should be placed near the calibration location to allow it to stabilize at the ambient temperature, which will prevail during its use.

When calibrating in compression the surface on which the lower boss will bear should be flat and have a hardness of Rockwell "C" Scale 50-55. If the surface does not meet these requirements, an auxiliary plate having these characteristics should be used under the boss. A soft steel pad should be inserted between the upper boss and the loading surface. The spherical surface of the upper boss will brinell a seat in this pad, assuring axial loading. The steel pad should be approximately 4" sq. x 0.5" thick for Ring Dynamometers having capacities up to 60,000 lbf, and 5" sq. x 1" thick for capacities up to 1,000,000 lbf. The surface, which applies the load to this upper boss pad, should also be flat and have a Rockwell "C" Scale 50-55.

Tension and Compression mode Ring Dynamometers are supplied with pulling rods having a spherical seated coupling at the connection with the ring and a spherical seated washer and nut at the outer end. This combination is intended to provide as much versatility as possible when making a tension set-up, but some auxiliary fittings such as spacers and washers may be needed.

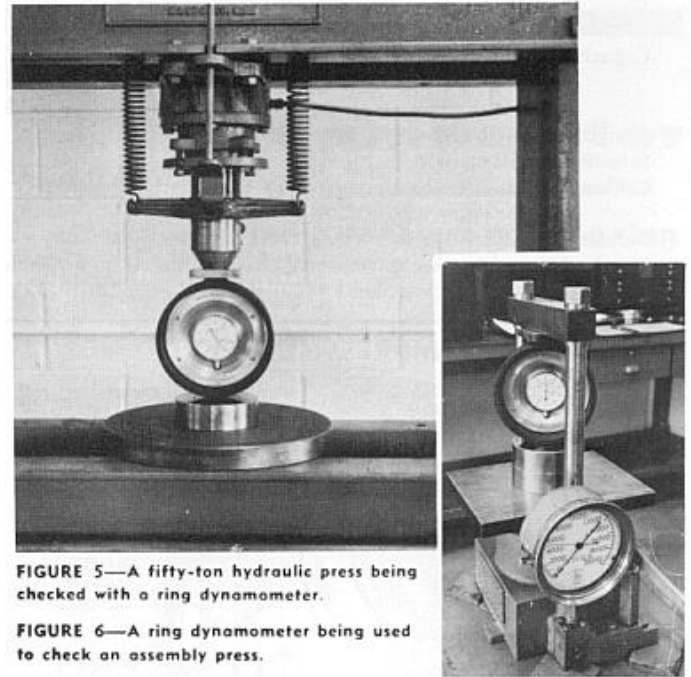

**FIGURE 5**—A fifty-ton hydraulic press being checked with a ring dynamometer.

**FIGURE 6**—A ring dynamometer being used to check an assembly press.

The spherical connectors will assist in aligning the Ring Dynamometer when it is set-up. Be sure to align the Ring Dynamometer as accurately as possible before the load is applied however, as no spherical bearing can be depended upon to adjust itself under load. When reading the Ring Dynamometer during tension calibration, the counter clockwise, red numbers are used.

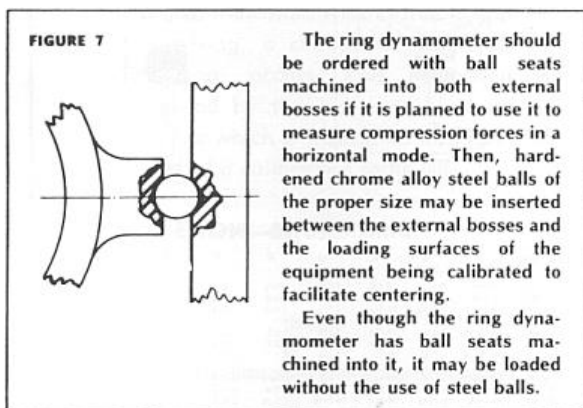

**FIGURE 7**

The ring dynamometer should be ordered with ball seats machined into both external bosses if it is planned to use it to measure compression forces in a horizontal mode. Then, hardened chrome alloy steel balls of the proper size may be inserted between the external bosses and the loading surfaces of the equipment being calibrated to facilitate centering.

Even though the ring dynamometer has ball seats machined into it, it may be loaded without the use of steel balls.

After these preparations have been made, a load equivalent to the maximum load to be checked, but not exceeding capacity of the dynamometer, should be applied. This stabilizes the dynamometer or any other elastic member in the system being checked. Apply the load to be calibrated and read the dial in divisions. Refer to the calibration report, which is supplied with the Ring Dynamometer and determine the load in pounds that applies to the dial reading. Note that three values are given on the report for each dial reading. The average of these three values is used as the load reading.

## Care and Adjustment

Since the accuracy of the ring dynamometer is directly dependent on the dial indicator, the instrument should be handled carefully. If the dial indicator shows evidence of malfunction, the ring dynamometer should be returned for repair and recalibration.

In operation, the zero setting of the dial indicator is made by rotating its bezel. Otherwise, the dial indicator has been positioned at assembly and normally should need no further adjustment. If, for some unusual reason, the dial indicator needs repositioning, it can be readily accomplished. Release the clamp screw in the center of the back of the ring dynamometer (see Figure 6) until the dial indicator is snugly seated. Then turn the adjusting screw (see Figure 6) to bring the indicator pointer to an approximate upright position. Tighten the clamp screw and complete the precise zero setting by turning the bezel of the dial indicator.

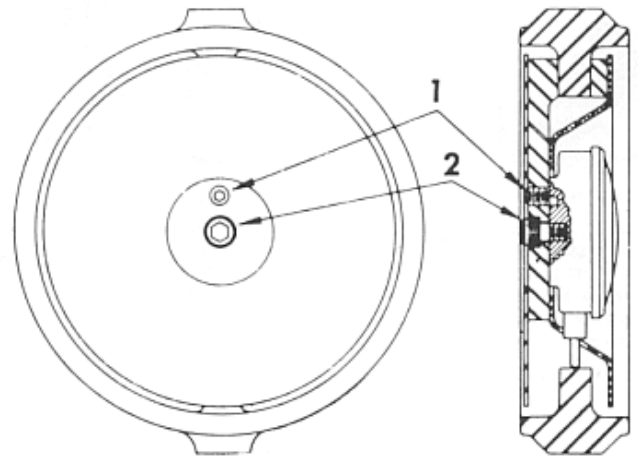

FIGURE 8 1—ADJUSTING SCREW 2—CLAMP SCREW

## Specifications

**Uncertainty:** 0.05% of range at calibrated load. (Equal to 0.5 lbf per 1,000 lbf capacity)

**Capacity Load Reading (approximate):** 10,000 lbf capacity and less – 925 divisions.  
10,000 lbf to 50,000 lbf capacity – 850 divisions.  
100,000 lbf to 300,000 lbf capacity – 650 divisions.

**Readability:** 0.2 division

**Sensitivity:** 0.1 division

**Calibration:** All Ring Dynamometers are calibrated in accordance with ASTM specification E74.

**Indicator Accuracy:** meets or exceeds A.G.D. specifications.

**Standard Capacities:** See dimensional charts below. (Also available in Kilogram, Newton, and special capacities.)

